

Minnesota
Lake and Watershed
Data Collection Manual

Table of Contents

1. Introduction
11. Lake Characteristics
 - a. Geography, geology, and of the lake basin
 - b. Physical parameters
 - c. Chemical parameters
 - d. Biological parameters
- III. Watershed Characteristics
 - a. Overview of process
 - b. Delineation and tributary identification
 - c. Land use assessment
 - d. Shoreland development
 - e. Tributary monitoring considerations
- IV. Ancillary Information
 - a. House to house septic system survey
 - b. Lake and watershed history
 - c. Lake uses
 - d. Climate data
 - e. Economic significance of lakes
- V. Monitoring Equipment, Sampling and Laboratory Considerations
 - a. Sampling equipment-construction and use
 - b. Where, how, when to sample
 - c. Laboratory considerations
- VI. Data Organization, Storage and Assessment
 - a. Data organization and storage
 - b. Data assessment and presentation
- VII. Summary and Conclusions
- VIII. References
- IX. Glossary and Acronyms
- X. Appendices

LIST OF FIGURES

1. Ecoregion map
2. DO and temperature plot
3. Secchi transparency and user perception plots
4. Secchi transparency trend detection
5. Total phosphorus plot
6. Lake zones map
7. Chlorophyll a and algal composition bar charts
8. Aquatic macrophyte mapping
9. Lake watershed delineation example
10. Sampling gear
11. Carlson TSI graphic

LIST OF TABLES

1. Levels of lake and watershed assessment
2. User perception scale
3. Shoreland development data
4. Stream water quality data example
5. Septic survey form
6. Septic survey analysis
7. Lake history examples
8. Importance of lakes to local economy worksheet
9. Lake monitoring variables

Chapter I

Introduction

Objectives

The purpose of this manual is to help people relate lake and watershed information to effective lake management. For some, participation may include water quality sampling or participating in an exotic species surveillance program. Others may be involved in assessing pollution sources in the watershed. Although there are many steps in this process, culminating in the development of a comprehensive lake management plan, the initial step is always the commitment by a person or group to collect information on existing lake conditions. Using this manual will increase the likelihood that the information collected will contribute to decisions that benefit the lake.

This manual should also help local officials who make development decisions and need additional information on the potential impacts on lakes. The manual will not, however, provide the details required by professionals for intensive lake and watershed investigations. Numerous comprehensive manuals already exist for that purpose.

Lake data collection often focuses on a particular issue identified by concerned lake users. This manual addresses several important lake management issues, and includes recommendations for the method and frequency of data collection and data reporting.

The manual is not a complete reference on aquatic biological and chemical interactions. Nor does it recommend specific management alternatives in a lake or watershed. Several sources for this kind of information are referenced in the manual for those who need it. The user is also encouraged to involve available lake management professionals, as well as other groups with lake monitoring experience.

Lake Information

Lakes are dynamic ecosystems that reflect their specific lake basin characteristics, variations in climate, and biological components. The size of the lake basin, its depth and volume, the size of the watershed contributing runoff to the lake, and the quantity and quality of water that enters the lake are important considerations. Lake management activities are often implemented on the basis of this information, including surface use regulations, aeration, native and exotic aquatic plant management, and swimming beach operation.

Important water quality issues include the biological productivity of a lake (trophic state), water chemistry profiles, regional water quality comparisons, nutrient concentrations, water transparency, beach water quality, specific pollutants, and historical trends.

Lake management issues related to the physical characteristics of the lake will require data on the surface area, shape, depth and volume of the lake. The inlet and outlet characteristics and bottom types are also important.

Issues related to use include access, the proportion of adjacent public lands, withdrawal rates and diversion, surface uses and use restrictions. This information can be obtained partially through user surveys.

Lake level management requires information on historic lake level trends, precipitation records, potential ground water interactions, outlet capacity, structure elevations along the shoreline, and lake basin characteristics.

Rooted aquatic vegetation management issues relate to the distribution and abundance of aquatic plants, recreation impacts, exotic species management including Eurasian watermilfoil, the history of chemical and mechanical control efforts, and lake basin characteristics.

Information related to the management of summer algae populations includes seasonal abundance and species composition, bloom frequency, nutrient concentrations, and recreational impacts. User surveys may be utilized to obtain some data.

Fisheries management requires information about aquatic habitats, survey data, historical management efforts, fishing pressure, winterkill potential, lake basin characteristics, and health advisory reports.

Watershed Information

Effective lake management depends on understanding the relationship between a lake and its watershed. Improving the quality of water entering a lake may reduce the need for ongoing in-lake maintenance. The pollutants in the watershed are usually related directly to land use activities. Watershed monitoring can identify the most important pollution sources and suggest the necessary land use management and controls. Watershed information may also identify barriers to lake management. For example, limited opportunities to develop sedimentation ponds, inadequate or disturbed water pathways, and historic wetland losses may hinder watershed improvements. Future land use activities can also be evaluated for potential impacts on lakes. Preventing a problem is usually more effective than correcting it. Local land and water resource management plans should reflect lake management strategies.

Watershed management depends on knowledge of watershed size, the ratio of watershed to lake surface area, present and future land use activities, soil and bedrock characteristics, slope, estimated loading of nutrients, water and sediment, the existing drainage system, information on existing, drained, and filled wetlands, shoreline characteristics and development, and climate.

Economic and Educational Information

The financial impacts of lake management can be related to information on lakeshore property and businesses, the estimated size of the user population, and regional economic impacts. Assembling information on the economic significance of lakes will help local officials make appropriate decisions regarding lakes and their watersheds.

Education is another important lake management tool. Data collection, analysis and presentation should be done so that it is understandable to students, lakeshore property owners, and others who may participate in lake management activities.

Levels of Lake and Watershed Assessment

It maybe wise to approach lake and watershed assessment in phases (levels), beginning with rather basic (low cost) and proceeding to more advanced (higher cost) assessment techniques, as manpower and budget allow. Table 1 presents a potential hierarchy of lake and watershed assessment.

The “basic” assessment level provides a good starting point in your quest for information on your lake and watershed. Upon completing this level of assessment, you will be able to characterize summer mean water quality conditions, lake level fluctuations, compare basic water quality and physical characteristics with other lakes in your ecoregion, understand fishery management of the lake, gain an appreciation of uses of your lake and problems that may be encountered. Further, basic assessment will place you in a position to communicate facts to shoreland property owners, lake users, and local officials. You are also well postured to begin developing a lake management plan. By completing a basic level of assessment, your association (local unit, etc.) will acquire information which is essential for managing your lake and help planning to proceed more efficiently and quickly.

As you move toward “intermediate” and “advanced” levels of assessment, additional expenses may be incurred and professional assistance maybe required. For example, tributary monitoring to develop an accurate nutrient budget in the “advanced” level would require numerous samples and could require the use of continuous flow gauges and automatic samplers.

This manual is organized by assessment focus.

Section II addresses in-lake assessment and includes geographic, physical, chemical, and biological parameters. Brief descriptions of parameters, methods of measurement, and notes on data assessment are included.

Section III addresses watershed assessment and includes information on delineating watersheds, identifying tributaries, assessing land uses, shoreland development, and tributary monitoring.

Section IV addresses some “miscellaneous,” but very important, assessments, which can be undertaken. Included in this section are house-to-house septic system survey, land water history, lake uses, climatic, and economic assessments.

Section V provides some examples of sample equipment construction and use, tips on when and where to sample and some laboratory and quality assurance considerations.

Section VI provides some additional suggestions for data organization and assessment.

A list of useful references, a glossary of terms, and list of acronyms are also provided. The references will provide you with more detail on topics addressed in the manual.

The appendices include additional figures (Appendix I), tables (Appendix II), and lists (Appendix III) referred to in the text. The figures and tables are generally provided as examples. However, some (figures and tables) may be incorporated directly into your assessment. The list of resource agencies, persons, and phone numbers should be useful as questions pertaining to lake and watershed assessment arise.

Future Data Applications

Developing a lake management database is an ongoing process. The initial scope of the effort will address the most fundamental concerns. As time, resources and additional interests develop, data collection can be expanded or redirected as necessary. An idealized lake management database will incorporate information on each of the major issues identified in this manual. This information can be classified into categories, which are useful for identifying and prioritizing management activities.

Comprehensive lake management involves the application of information to guide management decisions. A lake management plan can identify specific concerns and appropriate goals. The plan should recommend activities to meet stated goals, including the role of local government units, other agencies and residents. Financing and timelines for plan revision are other important components. The process of developing a lake management plan is described in a separate manual-*Developing a Lake Management Plan*.

TABLE 1. Levels of Lake and Watershed Assessment

— Characteristics —					
Level	Water Quality	Basin	Watershed	Biological	Socioeconomic
Basic	<ul style="list-style-type: none"> • Monitor once/month June-Sept. chemistry, D.O., chlorophyll • Secchi weekly June-Sept. • Use MINLEAP model 	<ul style="list-style-type: none"> • Determine surface area, mean depth, volume, and shoreline length • Monitor lake level 	<ul style="list-style-type: none"> • Delineate watershed boundary & determine area • Determine "ecoregion" lake is in • Define lake type (e.g. seepage, drainage) 	<ul style="list-style-type: none"> • Obtain current fisheries data from MDNR • Review historical macrophyte data 	<ul style="list-style-type: none"> • Determine uses of lake • Identify perceived lake problems, sources • Document problems
Intermediate	<ul style="list-style-type: none"> • Increase sample frequency to 6-10 samples May-Oct. • Increase # of sites • Establish rain gauges • Evaluate water quality trends • Use Reckhow and Simpson model 	<ul style="list-style-type: none"> • Determine geologic origin and setting of lake • Calculate percent littoral area 	<ul style="list-style-type: none"> • Determine land use composition • Locate all tributaries • Determine # of shoreland residences • Conduct septic survey • Determine soil types 	<ul style="list-style-type: none"> • Conduct macrophyte survey • Identify algae • Analyze current and historical fish survey and stocking data 	<ul style="list-style-type: none"> • Compile lake history • Document surface use conflict • Compile real estate values • Identify likely range of lake water quality goals
Advanced	<ul style="list-style-type: none"> • Monitor lake 8-10 times May-Oct. • Conduct limited tributary monitoring • Gauge stream flow • Estimate ground water influx-flow direction • Estimate nutrient loads • Use BATHTUB model 	<ul style="list-style-type: none"> • Determine volumes for individual basins • Calculate fetch length by basin 	<ul style="list-style-type: none"> • Conduct detailed land use • Delineate sub-watersheds • Locate all culverts and inlets • Locate any point sources, feedlots etc. • Inspect septic systems 	<ul style="list-style-type: none"> • Analyze fishery & stocking data for trends • Review Aquatic Plant Management permit history for lake • Review Fisheries Management Plan 	<ul style="list-style-type: none"> • Review permit history for shoreland alterations • Determine economic significance of lake • Set goals

Chapter II

Lake Characteristics

Various measures of a lake's morphometry (physical characteristics of basin), chemistry, biology, and physical composition are essential to understanding how lakes work and identifying management options. Many of these factors are interrelated. The initial focus is on parameters used to characterize the trophic status (nutritional status) and overall ecology of the lake. It is these parameters the lake manager will most frequently use as a basis for making management decisions for the lake. A brief description of important parameters, methods of measurement, and notes on data analysis follow. Further details on recording data, data analysis, and data presentation may be found in Chapter VI. Parameters are categorized as follows for this discussion:

geographic and **morphometric** parameters;

physical parameters—dissolved oxygen, temperature, clarity, and lake levels;

chemical parameters—nutrients (e.g. phosphorus), color, ionic (e.g. pH), and solids (e.g. total suspended solids); and

biological parameters—chlorophyll a, phytoplankton, zooplankton, macrophytes (rooted plants), and fisheries.

a. Geography, Geology, and Morphometry of the Lake Basin

Determining the geographic/geologic setting and the individual morphology of a lake basin is essential for characterizing the condition of a lake and understanding management potentials and limitations for the lake. This information is essential to the development of a lake management plan, and can often be gathered during basic or intermediate levels of assessment.

Locating the ecoregion in which the lake is located is a good geographic starting point (Fig. 1). Minnesota is characterized by seven ecoregions based on maps of land use, soils, land form, and potential natural vegetation. Information from other lakes in the same ecoregion will serve as an important basis for evaluating the condition of your lake and setting water quality goals.

Understanding the geologic setting of your lake (how your lake was formed) is important. The majority of Minnesota's lakes were formed as a result of continental glaciation. A comprehensive discussion of the origin of Minnesota's lakes may be found in Zumberge (1952).

Determining "lake type" (hydrologic type) is important and relatively easy. A classification proposed by Eilers et al. (1983) and others can be used for this purpose. The classification system is based on the presence or absence of surface inlets and outlets. Lakes with no surface inlets or outlets are defined as "seepage"; lakes with no inlets and a permanent outlet are defined as "headwater" (i.e. spring); lakes with both inlets and outlets are defined as "drainage"; and lakes with inlets but no outlets are defined as "inflow" (Rapp, et al. 1985). "Reservoirs," by definition, are man-made surface impoundments. Knowing the lake type will help in determining appropriate monitoring strategies for the lake and understanding the lake's sensitivity to excess nutrient inputs or acid deposition. For example, seepage or headwater lakes on bedrock in northeastern Minnesota may be potentially sensitive to acid deposition, whereas a drainage lake in a large watershed with thick soils would be less sensitive. Likewise, seepage and inflow lakes can be very sensitive to excess nutrient inputs which stimulate excess growth of algae and weeds. Since these lakes have no surface outlets (in contrast to drainage or headwater lakes) what goes in, stays in.

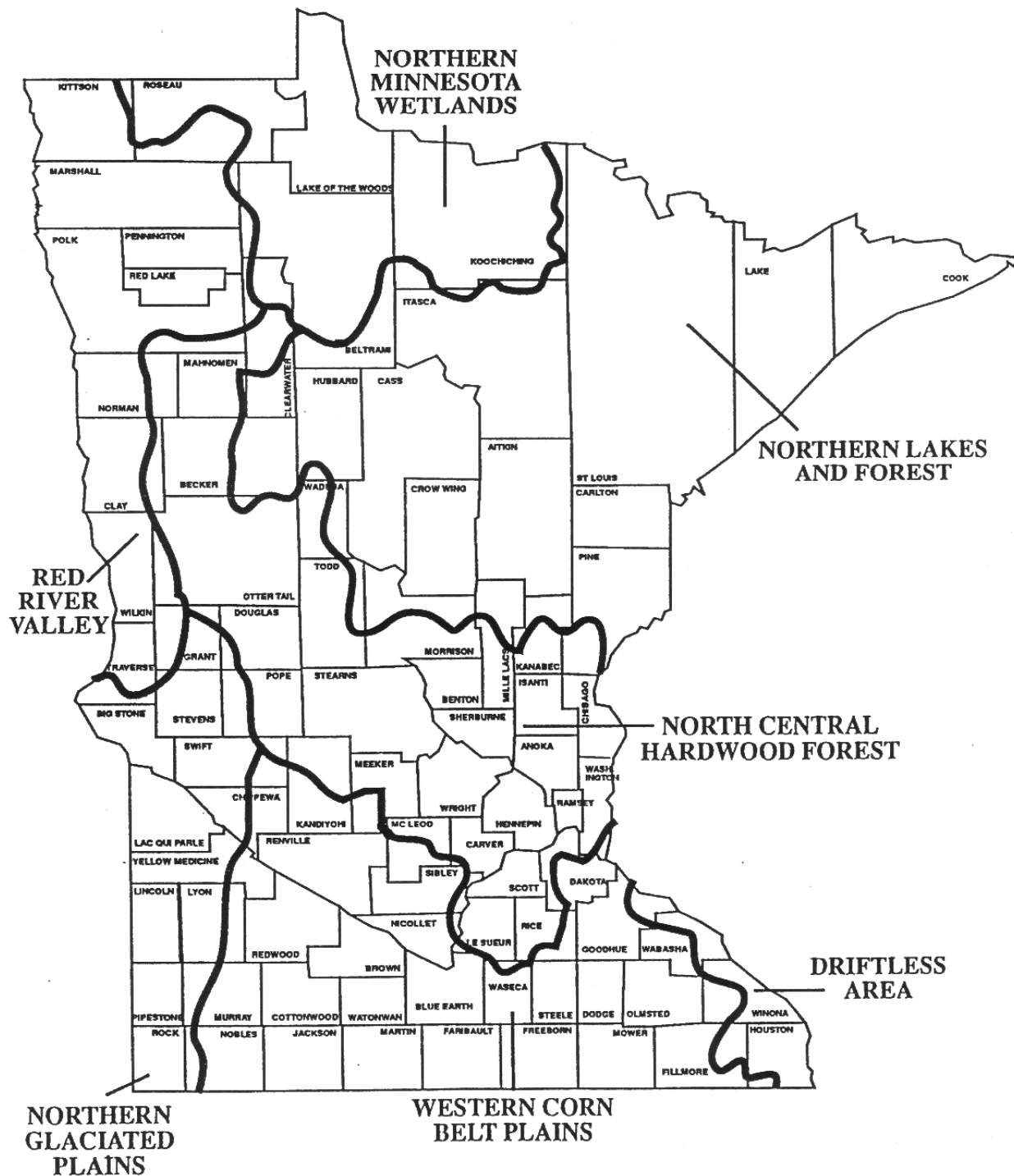

FIGURE 1. —Minnesota’s ecoregions as mapped by U.S. EPA. Ecoregions are areas of relative homogeneity that were developed from mapped information based on land and surface form, soils, land use, and potential natural vegetation.

A variety of measurements are used to describe the morphometric characteristics of the lake basin. Among the most important are surface area, volume, mean depth, median depth, maximum depth, maximum length, shoreline length, and percent littoral area. Most of these can be determined from a detailed contour (bathymetric) map prepared by the Minnesota Department of Natural Resources (MDNR). These maps are available through the “Minnesota Bookstore” (Appendix III). Some or all of these parameters may have been determined for your lake by the MDNR Fisheries Section or the Minnesota Pollution Control Agency (MPCA), Water Quality Division, or local water planning agency. It is advisable to see if the information exists for your lake prior to making the measurements yourself. Local engineering firms may be able to assist with these calculations, also.

An overview of these parameters, summarized primarily from Wetzel (1975), follows:

Area (A) - The surface area of the lake is commonly noted on the contour map. If not, it may be determined by planimetry (a device used to measure areas and distances on maps).

Volume (V) - The volume of the lake is computed as the integral of the areas of each stratum (layer or contour) at successive depths from the surface to the point of maximum depth. The volume can be estimated by summation of a series of truncated cones of a strata:

$$V = \sum h (A_1 + A_2 + A_1, A_2)$$

3

where **h** is the vertical depth of the stratum, A_1 the area of the upper surface, and A_2 the area of the lower surface of the stratum whose volume is to be determined. This can be a difficult measurement on deep lakes or lakes with a complex shape — seek assistance if you have any questions.

Maximum depth (Z_m or Z_{max}) — The greatest depth of the lake.

Mean depth (Z) — The volume divided by its surface area.

Median depth — The median depth contour on the contour map or the middle depth value collected from a survey when an actual contour map has not been developed.

Maximum length (l) — The distance on the lake surface between the most distant points on the lake, often referred to as the fetch. Lakes with a large fetch are very conducive to wind mixing.

Shoreline length — The length of the entire shoreline of the lake.

Percent littoral — This is the percent of the surface area of the lake basin less than or equal to 15 feet in depth. If sufficient light is available, this zone will contain extensive rooted aquatic plants. Lakes with a high percentage of surface area in the littoral zone tend to be very biologically productive.

b. Physical Parameters

Dissolved oxygen (DO) and temperature measurements are taken to characterize the presence or absence of thermal stratification and the amount of oxygen available for aquatic life in a lake, and are a routine part of a basic level of assessment. Measurements are taken by lowering a DO and temperature probe to specified depths (typically every meter from the surface of the lake to the bottom) and recording the DO and temperature at each depth. Conducting this sampling at defined intervals (e.g. monthly or weekly) from spring through fall should allow for a characterization of the mixing status of the lake. Mixing can be characterized as: *dimictic*—mixes during the spring and the fall; *polymictic*—mixes top to bottom throughout the summer; and *intermittent*—lake thermally stratifies for short periods of time during the summer. These characteristics can significantly influence the quality of the lake.

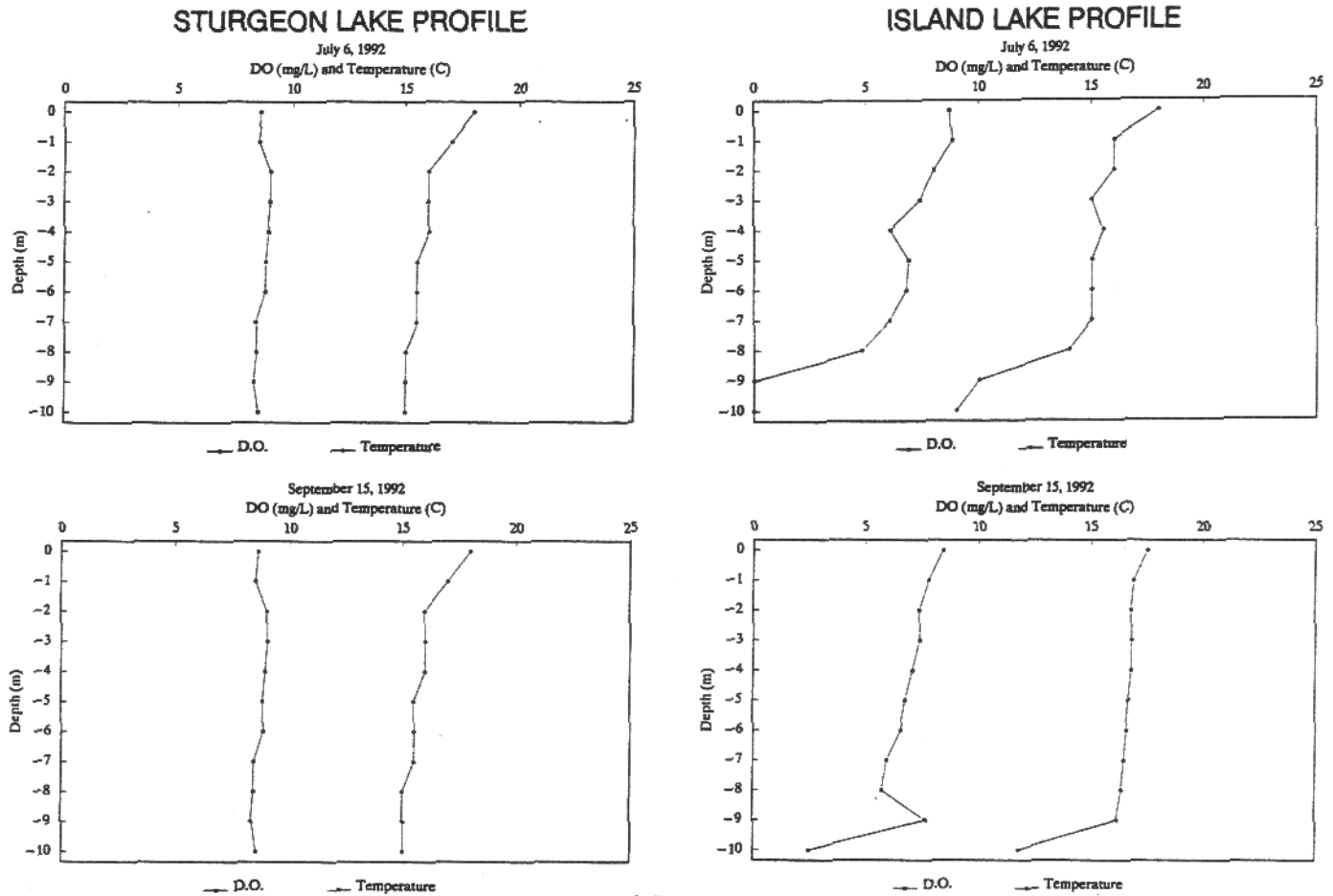

FIGURE 2. —Dissolved oxygen and temperature plots for a lake which mixes *intermittently* (Sturgeon) and a *dimictic* lake (Island). The *hypolimnion* (depth below 8 m) of Island Lake is anoxic on the July sample date. Fall overturn was occurring during the mid-September sample date.

Plotting the dissolved oxygen and temperature measurements versus depth for each sample date is a good means for determining whether and when the lake stratifies (i.e. mixing status), location of the thermocline, the presence/absence of oxygen in the bottom waters, and changes in oxygen and temperature over time (Fig. 2). *Thermocline* is the zone or layer of water exhibiting the largest reduction in temperature over the smallest change in depth. A reduction of greater than 1°C over one meter of depth often indicates the beginning of the thermocline.

Secchi transparency is a measurement of water clarity, and is considered an indirect measurement of the amount of algae or sediment in the water. As one of the three measures (and least expensive) used to characterize the *trophic* status of a lake (the others being chlorophyll *a* and total phosphorus) it is essential to any lake water quality monitoring program.

Secchi transparency measures are taken with a Secchi disk (a white, or black and white, eight-inch disk). The disks may be obtained inexpensively through MPCA's Citizens' Lake Monitoring Program (CLMP, Appendix III). The disk is lowered into the water until it disappears from sight and pulled back until it is again visible. The midpoint between these two points represents the Secchi depth. Measurements are typically taken on a weekly basis, from June through September.

In addition to Secchi measurements, it is desirable to make subjective judgments on the *physical appearance* and *recreational suitability* on each sample date. Table 2 presents the basis for making these judgments. Data recording forms provided through CLMP have space for recording this information. Perceptions of lake observers are used to help establish water quality goals for a lake. This information should be collected as a part of a basic assessment.

Plotting Secchi transparency over the spring through summer period provides a visual presentation of changes in transparency over time (Fig. 3). Individual plots for each sample site may be desirable. Changes in transparency can often be related to changes in the amount of algae in the lake. Humic coloration ("bog stain") or suspended sediments may also limit transparency in lakes.

A review of the user perception responses on the “physical appearance” and “recreational suitability” of the lake on each sample date should be compared to the Secchi data and, ultimately, to chlorophyll a concentrations. This may allow identification of “trigger levels” of transparency or chlorophyll a that may be unacceptable to the lake user. This will be useful in setting water quality goals for the lake, e.g. a phosphorus concentration that minimizes the frequency of nuisance blooms of algae or low transparency. This is often done in intermediate or advanced assessments.

If a number of years of transparency data are available, it may be helpful to calculate summer averages and plot them versus time. This is very valuable for demonstrating the variability in lake condition over time and can also provide a means to detect long-term changes in lake condition over time. If trend detection is of interest, it is essential that some appropriate statistics are applied, e.g. Kendall tau correlations, mean +/- standard error, etc. Without such statistics, erroneous conclusions might be drawn. In most cases, if trends are to be detected, it will require on the order of eight or more years of data, with 10 or more summer measurements per year. Fig. 4 (found in Appendix I) provides further information on trend analysis. This analysis is often done in intermediate or advanced assessments.

Lake level data are extremely important to Minnesota’s overall water management program. Lakeshore development and use are often adversely affected by water level fluctuations, such as potential flooding damage, drought-related access and aesthetic problems. Knowing and understanding the history of water level fluctuations on a particular lake can help in coping with these problems. Lake level data should be collected as a part of a basic assessment.

The water level on all lakes fluctuates, some more than others. In Minnesota, water level fluctuations in any year typically range between two to three feet; however, historic fluctuations in excess of 10 vertical feet have been recorded. Fluctuations can result from human activities, such as construction or operation of a dam, or acts of nature such as beaver activity, drought, and flooding. However, water level fluctuations are primarily a response to climatic events, such as short and long-term changes in the quantity and distribution of precipitation, and changes in the groundwater level.

Historic water level data are useful in developing computer simulation and prediction models of lake fluctuations. These data are used to estimate flood levels which, in turn, can be used by county zoning officials for prospective home buyers in locating building or sewage treatment system sites and for establishing low floor elevations for new construction. These data are also used for administration of MDNR’s public waters permit program, and as supporting data for establishing ordinary and historic high water elevations. Finally, watershed managers and planners use historic lake level data while preparing local water management plans and modeling lake water quality characteristics.

Table 2. Lake Observer Survey.

A. Please circle the one number that best describes the physical condition of the lake water today.

1. Crystal clear water.
2. Not quite crystal clear, a little algae present/visible.
3. Definite algal green, yellow, or brown color apparent.
4. High algal levels with limited clarity and/or mild odor apparent.
5. Severely high algal levels with one or more of the following: massive floating scums on lake or washed up on shore, strong foul odor, or fish kill.

B. Please circle the one number that best describes your opinion on how suitable the lake water is for recreation and aesthetic enjoyment today:

1. Beautiful, could not be any nicer.
2. Very minor aesthetic problems; excellent for swimming, boating, enjoyment.
3. Swimming and aesthetic enjoyment slightly impaired because of algal levels.
4. Desire to swim and level of enjoyment of the lake substantially reduced because of algal levels (would not swim, but boating is okay).
5. Swimming and aesthetic enjoyment of the lake nearly impossible because of algal levels.

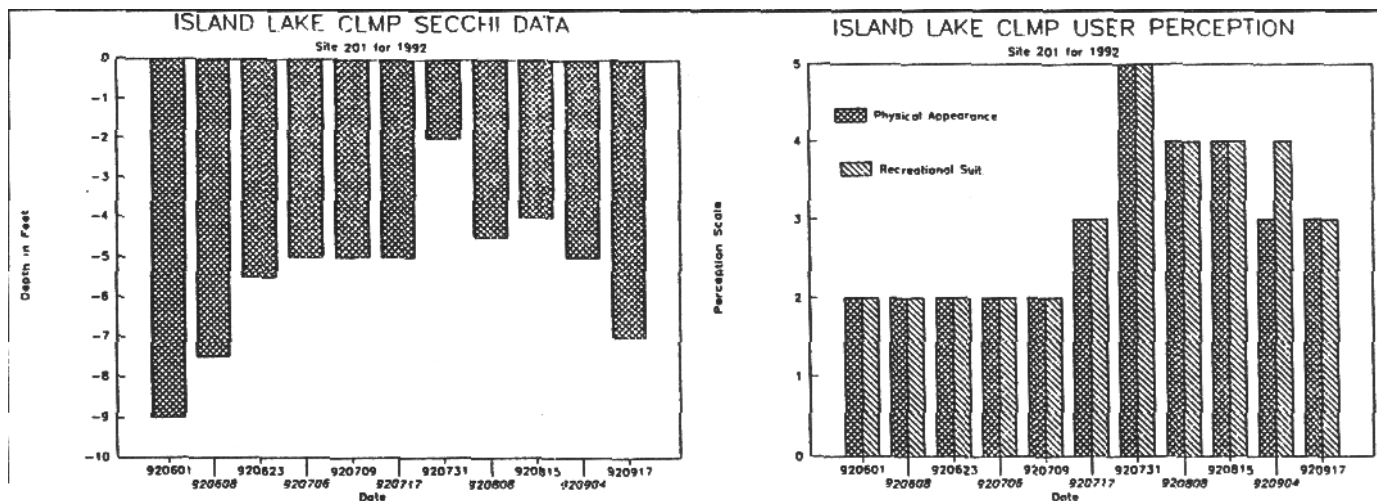

FIGURE 3. —Secchi transparency and user perception plots. Refer to Table 2 for the user perception scale. For Island Lake, transparencies of four feet or less were associated with conditions characterized as “no swimming” (4) and “high algal levels” (4) or worse.

The MDNR’s Lake Level Minnesota (LLM) program is comprised of approximately 600 permanent and temporary lake level gauging stations. Call the Division of Waters (DOW) at (612) 296-4800 for more information on the program.

The Division of Waters will install either a permanent lake level gauge on a structure, such as a bridge pier or dam abutment, or a temporary gauge. Temporary gauges are attached to a board fastened to a steel fence post driven into the lake bed next to your dock. The permanent gauges have advantages in that they are most stable and not subject to shifting, and can be monitored year-round. The advantage of a temporary gauge is that it can be installed near the reader’s residence. Temporary sites will be checked and/or installed each spring to make sure the “zero” reading is accurate within one hundredth foot in sea level datum.

A lake gauge is a heavy-duty measuring stick attached to a stake or structure for support. Gauge plates are enamel covered, metal measuring plates, four inches wide, accurately calibrated at every foot, tenth, and 0.02 foot. The number at the water line is read to the nearest one hundredth foot.

Lake gauges should be read at approximately the same time each week, and within 12-24 hours of a rainfall greater than 2 inches.

Ready-to-mail postcards for recording gauge readings will be issued either by mail or in the spring during the temporary gauge installation. It is a good idea to also record the readings on a calendar for back-up purposes. Submit these cards every 6-8 weeks, and note if new cards are needed.

Readings are entered into the DOW’s Lakes Database computer programs, where they can be analyzed and easily retrieved. Readers will be sent an annual report with a summary and graph of the water levels. Other reports can also be done upon request.

c. Chemical Parameters

In general, most of the chemical parameters we will discuss are collected from the warm surface waters (epilimnion) of the lake using an integrated sample. Samples may also be collected at discrete depths using a Van Dorn or homemade sampler. Chapter V summarizes the use and construction of sample equipment and sample handling. A more detailed discussion of water chemistry monitoring and analysis may be found in EPA (1991) or Wetzel (1975). Water chemistry data may already be available for your lake. Check with the MPCA, Water Quality Division (Appendix III) to see if data is available for your lake.

Nutrients—Phosphorus and nitrogen are essential plant nutrients that stimulate the growth of algae in most lakes. Elevated nutrient levels promote eutrophication. Of these two nutrients, phosphorus is often considered to be the nutrient, which regulates the production of algae in most lakes and is also the most amenable to control. Measuring phosphorus provides an indication of the fertility of a lake. Lakes with low concentrations of phosphorus are often referred to as oligotrophic, while lakes with high phosphorus concentrations are often referred to as eutrophic.

There are numerous forms of phosphorus and nitrogen, which can be measured in a laboratory. Total phosphorus represents dissolved phosphorus and phosphorus attached to particles (e.g. soil) in the water. It is the single most important nutrient to measure in a lake. Ortho-phosphorus represents the dissolved reactive phosphorus in the water (sometimes referred to as soluble reactive phosphorus). It is a measure of the phosphorus which is readily available for use by algae. It is an important measure to consider in comprehensive lake and watershed studies (e.g. advanced level).

In addition to epilimnetic samples of total phosphorus, it is often advisable to collect samples from the deeper, cooler waters (hypolimnion) during the summer. These measurements will help you evaluate whether substantial amounts of phosphorus are being released by the sediments.

Plotting epilimnetic total phosphorus concentrations from spring through fall and comparing epilimnetic concentrations to hypolimnetic phosphorus concentrations can provide some indication as to the importance of the internal release of phosphorus from the sediments and seasonal changes in phosphorus concentrations in the lake (Fig. 5).

The forms of nitrogen of most interest in lake studies are total Kjeldahl nitrogen (TKN) which includes ammonia-N and organic-N. Total Kjeldahl plus nitrite + nitrate N represents total nitrogen (TN). Nitrite + nitrate N are very soluble in water and are readily used by algae. Concentrations of nitrite and nitrate are frequently so low that they are at or below the ability of a laboratory to detect them in a sample (detection limit). Of the forms of phosphorus and nitrogen discussed, total phosphorus and total Kjeldahl nitrogen are the most important to measure.

Solids—There are a variety of parameters which provide information on the amount of dissolved and suspended material in lake water. Suspended materials influence the transparency, color, and overall health of the lake ecosystem and may need to be considered in the management of the lake. Total suspended solids (TSS) and turbidity are two common measures of the amount of suspended particles in the water. Turbidity is a measure of the light scattering properties of the suspended materials. These measures do not differentiate between inorganic (e.g. clay) and organic (e.g. algae) matter in the water.

Measuring the total *suspended volatile solids* (TSV) can help you to differentiate between the TSS contributed by algae (organic) versus that contributed by soil particles (inorganic). Subtracting TSV from TSS yields the *total suspended inorganic solids*. High levels of suspended inorganic solids may severely limit the light available for rooted plant and algae growth.

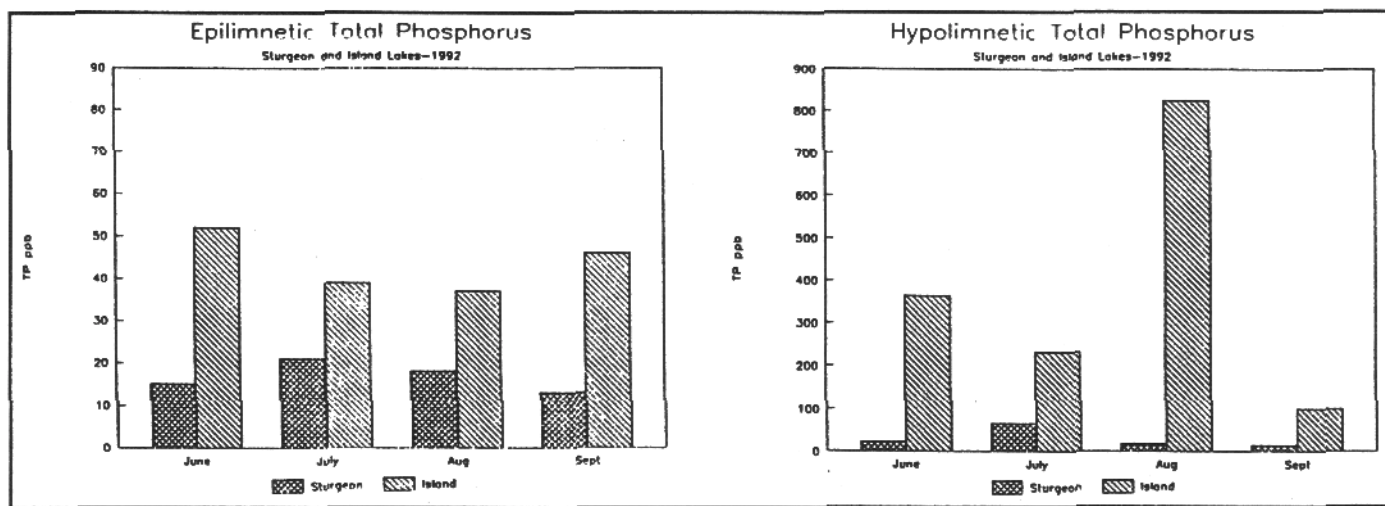

FIGURE 5. —Epilimnetic and hypolimnetic phosphorus plots. A comparison of a mesotrophic lake which mixes intermittently (Sturgeon) and a eutrophic lake which remains stratified during the summer (Island). Epilimnetic P concentrations decline over the summer in Island Lake until fall overturn and mixing with the P rich hypolimnetic waters occurs. (Note the difference in scales between epilimnetic and hypolimnetic plots.)

Water *color* or *true color* (as measured relative to a platinum-cobalt, Pt-Co, standard) as it may be referred to, is often an important measure in lakes. Lakes with large amounts of incompletely dissolved organic compounds in the water may appear “coffee colored.” Waters draining from peatlands are frequently the source of this “humic matter.” At very high color values, this humic matter may limit the transparency of the water. In general, waters with color values

less than 20 Pt-Co Units would be considered clear; 30-50 Pt-Co Units, moderate (coffee coloration becomes evident at about 30 Pt-Co Units); and greater than 50 Pt-Co Units would be considered dark.

With the exception of color, most of the “solids” measurements need not be collected in a basic assessment. They should, however, be included in intermediate or advanced assessments.

Ionic measurements—The amount and types of dissolved minerals (ions) in the water are of general interest for describing the overall ionic chemistry of the lake and influences aquatic life such as plants and fish. The parameters which describe the ionic characteristics of the water include: alkalinity, conductivity, chloride, hardness and pH. These parameters measure the positive or negatively charged ions dissolved in water. They generally reflect watershed characteristics.

The alkalinity is a measure of the buffering capacity of the waters. Lakes in regions of the state with thick soil cover and some limestone present will have moderate to high alkalinities. Lakes in regions with thin soils, or lakes on bedrock, may have very low alkalinity. Acid rain impacts may be a concern for lakes with alkalinities less than about 5 mg/L.

Conductivity is a simple measure of the dissolved minerals in the water. Lakes with high alkalinity often have high conductivity and vice versa. Lakes with low conductivity would be considered “soft,” and high conductivity “hard.” Total dissolved solids is a companion measurement and may not be necessary. *Hardness* is a measure of the amount of dissolved calcium and magnesium in the water.

Chloride ions may increase in some urban lakes because of snowmelt runoff high in salt from road de-icing. Because it is a “conservative” (not used by freshwater plants or animals) ion, chloride will remain in the lake water.

The *acidity* of the water as measured by pH is of concern to aquatic life, with a desirable range between 6.5 to 9.0. Hard water (eutrophic lakes) often have pH values higher in the range, while soft water (oligotrophic lakes) may be lower. The pH will fluctuate daily and seasonally in response to algal photosynthesis, runoff, and other factors. The ionic parameters need not be measured in a basic assessment, unless they can be measured inexpensively, e.g., field measures of pH or conductivity. They should be incorporated into intermediate or advanced assessments.

d. Biological Parameters

Information on the biota, including fish, plants and invertebrates, may be available for your lake. Before undertaking a biological survey or assessment of your lake, check with the local MDNR area fishery office (Appendix III) to see what is available. If you are interested in a fishery survey, it will be necessary to work with the area office, since MDNR is the agency responsible for fishery surveys in Minnesota. Fishery survey data is available for over 4,000 lakes, and is available through the area offices or the central office in St. Paul.

Most lakes can be divided into three basic zones or communities: the shoreline or *littoral* zone, the open water or *limnetic* zone, and the deep-water or *profundal* zone (Fig. 6). The *littoral* zone extends from the shoreline and includes the area of rooted plants, called *aquatic macrophytes*, such as water lilies. This aquatic macrophyte community serves an important role by producing oxygen and a diverse habitat for many different animals, including birds, insects, fish, and crustaceans.

The *limnetic* zone, or open-water zone, is inhabited by certain species of fish and free-floating plankton. The major components of a lake’s plankton community are zooplankton (microscopic animals) and phytoplankton (algae). The *zooplankton* include crustaceans and other microscopic animals without backbones (invertebrates). They are secondary consumers which feed upon bacteria and phytoplankton and are, in turn, consumed by fish. Because of their role as grazers in the aquatic environment, they are very important to a lake’s ecosystem. Not only are they a vital part of a lake’s food web, but large-bodied (> 1 mm or so) zooplankton such as *Daphnia pulcaria* can intensively increase water clarity by severely grazing on phytoplankton.

LAKE COMMUNITIES

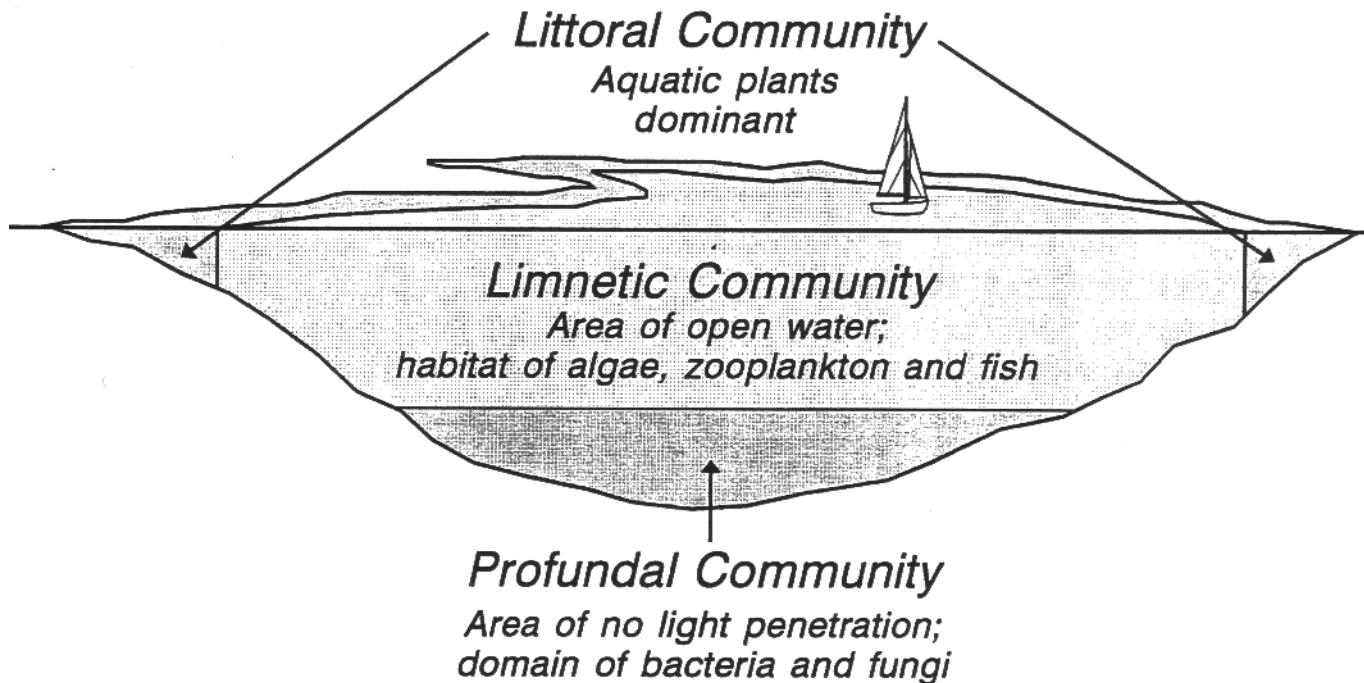

FIGURE 6. —Lake zones (communities) map.

These crustaceans (zooplankton) are the freshwater relatives of shrimp and lobsters which, under the microscope, look quite similar to their larger marine cousins (New York Department of Environmental Conservation, 1990). They vary in size, and may migrate vertically through the water column each day; moving toward the water surface at night to graze and sinking at dawn to hide from the feeding fish.

Phytoplankton, which make up the plant component of the plankton community, are also very important to the inner workings of a lake. Not only do they grow suspended in water, take up nutrients from surrounding water, and serve as the base of a lake's food chain, they also convert sunlight, water, and carbon dioxide into chemical energy in the form of simple sugars and oxygen. This conversion process is called photosynthesis and utilizes a pigment produced in plants (chlorophyll) to synthesize simple sugars from sunlight, with oxygen as a by-product. Therefore, oxygen production by way of photosynthesis is limited to water depths penetrated by sunlight. The sunlight penetration depth can be measured with the use of a Secchi disk, and is generally considered to be approximately twice the depth of the Secchi disk reading.

The main photosynthetic molecule behind this energy producing process is *chlorophyll*. There are, however, different forms of chlorophyll (chlorophylls *a*, *b*, *c*, *d*, and *e*). While each perform the same basic task (absorbing light waves), they each absorb a different range of the light spectrum. Of these different types of chlorophyll, chlorophyll *a* is found in all photosynthesizing plants, and is the master pigment found in blue-green algae (a common problemalga). For this reason, the algal biomass in a lake is commonly estimated by the lake's chlorophyll *a* concentration. The preferred measure is chlorophyll *a*, corrected for pheophytin *a*. Pheophytin *a* is a common degradation product of chlorophyll *a* that can interfere with the measurement of chlorophyll *a*. If phytoplankton populations are dense (especially during blue-green algal blooms), the water will become noticeably green, will have a lower than normal transparency, and a greater chlorophyll *a* concentration. The measurement of corrected chlorophyll *a* is essential to a basic assessment.

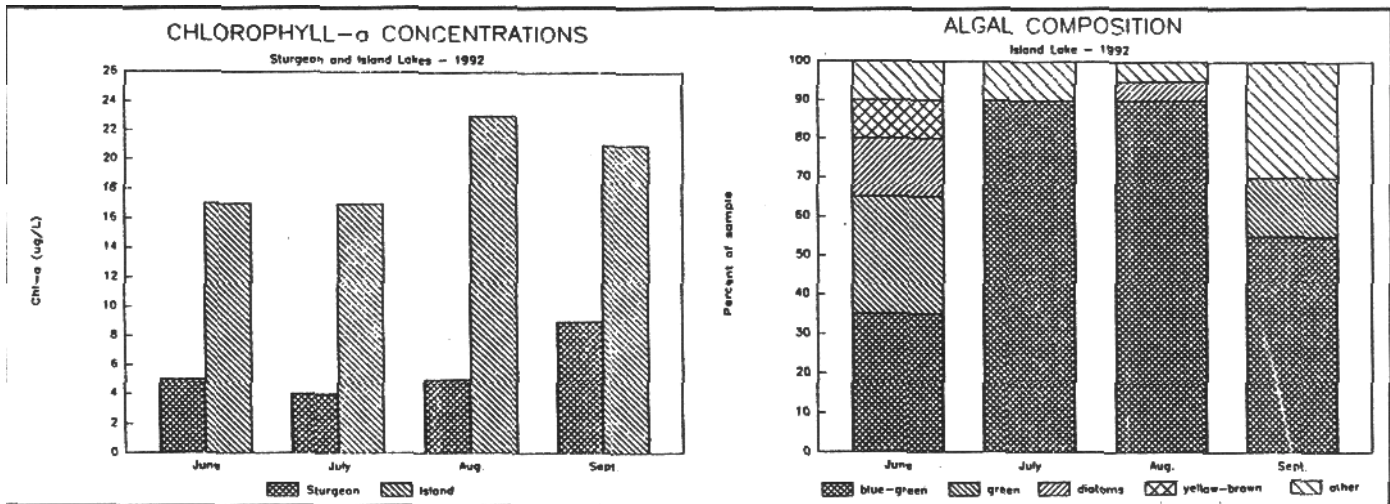

FIGURE 7. —Chlorophyll a and algal (phytoplankton) composition bar charts. Note: algal blooms on Island Lake during July through September were dominated by blue-green algae. CLMP volunteer characterized lake condition as “no swimming” (4) or worse and “high algal levels” (4) during this period of time (see Fig. 3).

Three important groups of algae are *diatoms*, *green algae*, and *blue-green algae*. Generally, diatoms show spring and fall population peaks in dimictic lakes with oligotrophic waters. The spring peak is associated with the formation of the thermocline, while the fall diatom peak is caused by nutrients suspended at the start of the fall overturn. As a lake becomes more eutrophic (more nutrients), there is less depletion of nutrients by spring diatoms, and more excessive phytoplankton growth (blooms) during the summer months. These summer phytoplankton blooms generally come in the form of green algae and blue-green algae. They can reduce water clarity, change the color of the lake, and smell bad. Algal identification is an important part of intermediate and advanced assessments.

Plotting chlorophyll a concentrations by sample date is one means for depicting changes in chlorophyll a (algal biomass) over time (Fig. 7). If algae are identified, it is often helpful to characterize the dominant type of algae on each date in terms of a pie graph or bar chart. Commonly, blooms of blue-greens may generate complaints by lake users more often than other forms, such as green algae.

Rooted aquatic plants

Minnesota lakes are home to a rich variety of rooted aquatic plants (macrophytes). They play a unique role in maintaining healthy lakes with good water clarity and abundant fish and wildlife populations.

Like their counterparts on land, aquatic plants stabilize bottom soils and prevent shoreline erosion. They reduce excessive nutrients in lakes through uptake and growth, while protecting bottom soils from wave action that can release phosphorus and nitrogen into the water.

Macrophytes provide important habitat for aquatic life. Some types of algae (periphyton) attach themselves to plants instead of floating freely in the water. Together with the rooted plants, they filter nutrients from the water and provide a place for small snails, immature insects, and tiny crustaceans to feed and live. Although unnoticed by most people, these small animals are one of the most important links in the food chain.

Larger fish and many species of wildlife also depend on aquatic plants for a place to live. Some, like the muskrat, eat the plants themselves. Others, like waterfowl, loons and otters, feed primarily on the small animals or fish that live within aquatic plant beds. Aquatic plants provide critical nesting areas to many birds, such as loons and black terns. Some fish, such as largemouth bass and sunfish, need beds of native vegetation for successful spawning or use it to hide from predators. Bass and other predator fish use the edges of vegetation beds for cover to ambush prey.

Plants that grow from the lake bottom and extend above the surface of the water are called *emergent* vegetation. The most easily recognized are cattails and bulrushes, although wild rice, arrowhead and others are common to some lakes (Table 1, Appendix 11). Emergents are generally restricted to shallow water, less than one meter deep, and generally grow more thickly on soft bottom soils.

Plants that grow entirely underwater, or extend only to leaves floating on the surface, are called *submergent*. Submergents can substantially reduce wave action in shallow water. Like emergents, submerged aquatic plants are usually the most dense when bottom soils are muck or soft silt.

Other factors affecting rooted aquatic plants are available nutrients, water clarity, bottom disturbance and competition. All plants require nutrients to survive. In most lakes, phosphorus is the nutrient with the greatest affect on aquatic plant densities.

Water clarity plays a critical role in how deep aquatic plants will grow. Native aquatic plants will generally grow to a depth 1 to 1-1/2 times the Secchi disk reading. Some shallow lakes with excessive wave action or high carp populations which stir up the sediments may have no submerged aquatic plants because water clarity is so poor. Temporarily lowering water levels to eliminate carp and allow sunlight to reach the bottom can help aquatic plants get started and maintain themselves after water levels return to normal. Cutting, herbicides, excessive powerboat wakes, and the rooting of carp create disturbances that reduce aquatic plants. Some species, particularly exotics such as Eurasian watermilfoil, seem to withstand disturbance better than others.

Competition can play an important role in determining what species of aquatic plants occur. Species native to Minnesota have adapted over thousands of years to conditions common in our lakes. Each species has a particular set of ecological conditions (niche) in which it does best. When competing for the same space, the species that will eventually win is the one best adapted to existing conditions.

Common cattail, for example, will out-compete hardstem bulrush when the lake bottom is silt or muck. As the soils become firmer and sandier, the bulrush will become more competitive. Exotic plants tend to dominate situations less than ideal for native species. Eurasian watermilfoil, for example, thrives when water clarity is poor or native plants have been lost to disturbance. It grows rapidly to the surface where it forms a dense mat of leaves to absorb sunlight.

Aquatic plants are important biological indicators of ecological health. Monitoring the species composition, density, and depth of aquatic plants provides important insights into lake quality. Detailed surveys are expensive in terms of time and required expertise. However, simply mapping the occurrence and general type of vegetation can be useful in describing lake quality trends. Be sure to check with the local DNR fisheries office before investing time or money for a vegetation survey. The lake may already have been surveyed or scheduled for a survey in the near future. Macrophyte surveys should be conducted as a part of an intermediate or advanced assessment.

Consider the lake in terms of four depth zones: 1) emergent zone (1 meter or approximately 3 feet); 2) shallow submergent zone (1-2 meters or approximately 6.5 feet); 3) deep submergent zone (2-4.6 meters or approximately 15 feet); and 4) deep water zone (deeper than 15 feet). Record the type (emergent or submergent) of vegetation, if any, in each zone. Emergent vegetation can be recorded from visual observation or recent aerial photographs, if available.

Submergent vegetation can be observed visually in some cases; however, along handled rake or grappling hook will usually be necessary. A grappling hook can be easily constructed with an eye bolt, metal conduit, and smooth 9 gauge fencing wire.

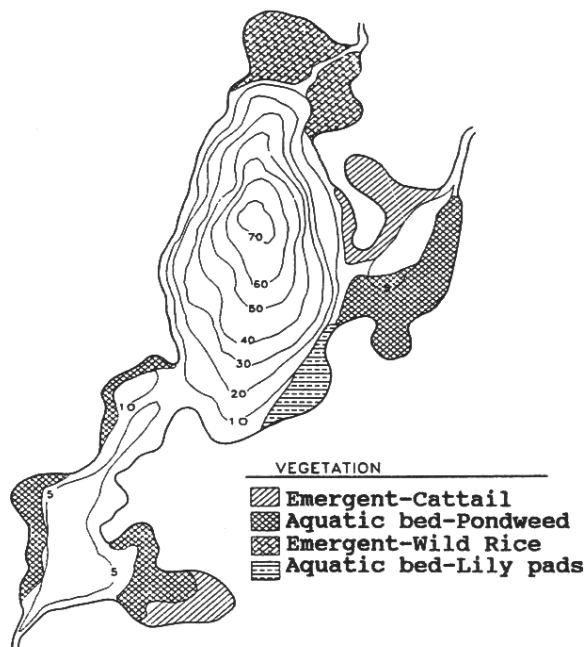

FIGURE 8. —Aquatic macrophyte mapping. Note vegetation types, location, approximate percentages, and date of mapping.

To map areas of macrophyte growth, transects should be established that extend from known points on shore toward mid-lake. The starting point should be easily recognizable and recorded so that it can be repeated in following years. A depth map and compass are invaluable in establishing the direction of the transect and location of sampling points. A recording form, such as that included in Appendix II, may be helpful also.

Record the extent of the vegetation within each depth zone on the map (Fig. 8). Type the vegetation as Emergent or Aquatic Bed (for submergents) if the vegetation covers 30 percent or more of the bottom. The type can be made more descriptive by listing the dominant vegetation from Table 1 (Appendix II) or by using a handbook such as *Key to Common Aquatic Plants of Minnesota* (Carlson and Moyle, 1968). A cattail stand, for example, would be listed as Emergent-Cattail. Vegetation should be surveyed between mid-June and mid-August. Conducting the survey annually, or every few years, will build a suitable database for determining vegetation trends. Additional information on macrophyte survey may be obtained from the *Manual of Instruction for Lake Survey* (MDNR, 1993). The manual is available for review at MDNR area fishery offices.

Fisheries

A lake's fish population often receives more attention than any other biological element. Each fish species will have different habitat needs. In addition to species, each population is characterized by age and size classes. The interactions between species and size classes can have a direct affect on water clarity, zooplankton, and aquatic plants.

The smaller fish in any lake provide the food base for larger predatory fish. These smaller fish rely heavily on insect larvae and zooplankton for nourishment. Aquatic plants provide feeding areas and protection from predators.

Fish populations can be managed to emphasize certain species and size classes. The populations are generally managed using three techniques. First, and most important, fish habitat must be protected, restored or even enhanced. Each species has requirements for pH, dissolved oxygen, temperature, the absence of toxic materials, rooted aquatic plant density, bottom type, the presence of tributaries and other factors. Food type and density also are important.

A second technique is population manipulation. This may include stocking or, in extreme situations, the removal of undesirable or competing species from the lake using a poison, such as rotenone. This is usually followed by stocking more desirable species. Stocking is based on careful consideration of habitat angling pressure and existing fish populations. Rarely, a forage species will be stocked in an attempt to modify the lake's food web.

Finally, the regulation of angling pressure through size or creel limits (number of fish), seasonal or tackle restrictions, or limiting access to sensitive areas may be used to improve the survival of desirable species or size classes.

The management of fish populations in a lake requires the knowledge and experience of professional fisheries biologists. Their effectiveness is dependent on sound information concerning the age and size distribution of each species. Fish are counted using gill nets, trap nets, seines, electro-fishing, and angler surveys. The technique selected depends on the fish species and the habitat where it is found.

Results of these surveys are available to the public along with a specific plan for fish populations in that lake. A review of survey results can be conducted during the basic level of assessment. Minnesota Department of Natural Resources fisheries personnel can provide valuable information for interpreting population surveys, including a comparison with similar lakes. Actual fishery surveys need to be conducted by MDNR fisheries staff. The local area fishery office will know the schedule for fishery surveys of your lake.

Exotic species

"Exotic" species are organisms introduced into habitats where they are not native. They are considered "biological pollutants" and a major cause of habitat degradation.

Introducing species from one habitat into another is risky business. Freed from the predators, parasites, pathogens, and competitors that kept their numbers in balance, exotic species often overrun their new home and crowd out native species. Once established, exotics can rarely be eliminated.

Most species introductions are the work of humans. Some introductions, such as carp and purple loosestrife, are intentional and do unexpected damage, but many exotic introductions are accidental.

The recent development of fast ocean freighters has greatly increased the risk of new exotics in the Great Lakes region. Ships take on ballast water in Europe for stability during the ocean crossing. This water is pumped out when

the ships pick up their loads in Great Lake ports. Because ships make the crossing so much faster now and the harbors are often less polluted, more exotic species are likely to survive the journey and thrive in the new area.

Many of the exotic plants and animals found in Minnesota arrived in the Great Lakes this way. Exotics are now being spread on boats and other recreational watercraft and equipment. A list of Minnesota exotics found in our aquatic environment can be found in Table 3 (Appendix II).

Identification of exotic aquatic infestations and monitoring exotic development is critical to dealing with their impacts on lake ecosystems. Volunteer monitoring can play a critical role in these efforts, particularly for exotic plants. For example, the best time to monitor purple loosestrife is during late summer when its flowers are in full bloom and it is readily apparent along shorelines and in wetlands. Eurasian watermilfoil is best monitored in late spring and early fall when water clarity is at its best and native plants are not at their peak.

Minnesota DNR Fisheries Lake Surveys are an important tool for monitoring exotics. Monitoring for exotics can be done as a part of a basic or intermediate assessment.

Information on the occurrence of exotic aquatic species or their identification should be reported to the MDNR, Section of Ecological Services, 500 Lafayette Road, St. Paul, MN 55155-4025 or the local MDNR fisheries office.

Chapter III

Watershed Characteristics

a. Overview of Process

A watershed is the land area that drains into a wetland, lake, stream or river. Knowing the boundaries of the watershed is a very important aspect of lake management. Rainfall or melting snow within a lake's watershed which does not evaporate will eventually flow into the lake either directly as surface runoff or indirectly through subsurface flow and groundwater. Activities within the watershed, therefore, have a direct impact on the lake.

Many long-time lakeshore residents know the major streams that enter their lake and the general nature of the surrounding watershed. However, until the watershed is drawn on a map, it is very difficult, to have a full appreciation of the watershed and the potential activities within the watershed that will have an impact on the lake. This should be done as a part of a basic assessment.

Once the watershed has been delineated, its overall nature can be assessed. The size of the watershed should be compared to lake size. The various watercourses, whether natural stream, farmland drainage ditch tiles, or urban storm sewer, should be identified. The number, location, and size of existing and drained wetlands within the watershed should be determined. In addition, identifying the percentage of the watershed that is urban, crop land, forested or pasture land is important (intermediate and advanced assessment).

Once watershed characteristics have been identified, sources of potential problems and solutions may become apparent. Nonpoint source pollution is directly related to land use activities. Land use activities with the greatest pollution potential include construction areas, impervious surfaces such as roads, commercial centers and parking lots, high density residential areas, agriculture, animal feedlots and septic systems. Land area that is being considered for development in the future should also be a high priority for evaluation of potential impacts on a lake.

Land use information can be obtained from city and county planning and zoning offices and county water plans. In addition, county extension, as well as soil and water conservation districts, are sources of summary information related to agriculture activities, and critical erosion and sedimentation areas.

Best management practices, or BMPs, have been identified for a variety of land use activities. For example, the MPCA's manual, *Protecting Water Quality in Urban Areas*, is a resource for urban BMPs. This manual and comparable manuals for agricultural and forest BMPs are available from the MPCA, Water Quality Division (Appendix 3). In agricultural areas, soil and water conservation districts and the USDA Soil Conservation Service (SCS) have conservation practice manuals for agricultural nonpoint pollution control.

An important role of individuals interested in the management of a lake is to incorporate appropriate BMPs into their own activities. Examples include soil tests to guide lawn fertilizer application rates, keeping fertilizers and soil off impervious surfaces where they flow directly into storm sewers, leaf litter control, composting sites located away from the lakeshore, vegetation strips along the shore, maintaining of septic systems and cleaning up pet wastes.

b. Watershed Delineation and Tributary Identification

Topographic maps are the primary tool to determine watershed boundaries. The shape of the land, portrayed by contours, is the distinctive characteristic of topographic maps. Contour lines on topographic maps are imaginary lines following the ground surface at a constant elevation above sea level. Contour interval is the regular elevation difference separating adjacent contour lines on maps.

The most widely used topographic maps are prepared and published by the U.S. Geological Survey (USGS). The USGS publishes topographic maps at various scales; the most widely used maps are at a scale of 1:24,000, or 2000 feet to the inch. Contour lines are generally shown for every 10 feet of vertical elevation change on USGS maps. Some maps show contours at every 5 feet of elevation difference for areas of the state with minimal topographic relief (e.g., Red River valley). Each map at a scale of 1:24,000 covers an area of about 55 square miles, measuring 7.5 minutes in both latitude and longitude. These maps are available directly from the USGS (East Distribution

Branch, 1200 South Eads Street, Arlington, VA 22202), some sporting goods stores, specialty map stores, and county Soil and Water Conservation District (SWCD) offices.

In 1969, the MDNR delineated all minor watersheds for the state. A total of 5600 minor watersheds were delineated, each having an area of at least 5 square miles. A total of 80 major watersheds were also identified. A map of the nine drainage basins and 80 major watersheds is included in Appendix I. The watershed boundaries are traced on a clear acetate overlay on USGS 7.5 minute topographic maps. This set of maps is housed in the MDNR Division of Waters office in St. Paul and is available for inspection. These maps may prove useful for lakes having a large watershed. County water plans should also contain a map showing major subwatershed boundaries within the county. The MDNR minor watershed maps provide a good starting point for understanding regional flow patterns for the area in which your lake is located. A review of the appropriate map is useful prior to delineating the specific boundary for your lake.

Being able to read and understand a USGS topographic map is a skill needed to delineate watershed boundaries. One needs to visualize the landscape portrayed by contour lines, primarily by making the distinction between a ridge and a valley, and then noting which way the land slopes. More information on reading and understanding topographic maps can be found at your local library. The librarian should be able to direct you to the proper references.

The first step is to identify all tributaries entering the lake. Watercourses are depicted by blue lines on the USGS topographic maps. Identifying the tributaries will give a general indication of the extent of the watershed. Compare water surface elevations of nearby lakes to also get a general indication of the direction water flows. On the example watershed delineation (Fig. 9) note that the water surface elevations shown on the map for Cedar and Caron Lakes are 1056 feet and 1052 feet, respectively.

The lake's outlet channel is a convenient place to start the delineation. Carefully examine the contour lines and draw arrows on the map (in pencil) showing the general direction of flow. Draw a line at the top of the ridge or hill that defines the watershed boundary. Continue delineating the watershed boundary around the lake until you return to the outlet.

For some lakes, the watershed boundary can be easily and accurately determined from the USGS topographic maps. However, in many areas of the state, delineating watershed boundaries is a test of map reading skills, especially in areas of the state where drainage is not well defined. In these areas, the USGS 7.5 minute topographic maps with 10 foot contour intervals do not show enough detail. The USGS topographic maps will not always show whether small depressions, wetlands, and even lakes have an outlet, nor will all culverts and small bridges be shown. Make your best judgment and follow up with field checks.

Initially, delineate the total watershed area. The *total watershed* includes all areas that potentially could drain into the lake. However, within the total watershed area, there may be landlocked areas that basically have no outlet. All water stays within a landlocked basin, even following heavy rainfall. Segregating these landlocked areas will define the *contributing watershed* area. The example shown for Cedar Lake (Fig. 9) includes a relatively large portion of the total watershed south and west of the lake which may not contribute runoff.

Additional sources of information may be available. Aerial photographs will sometimes show information not shown on the topographic maps. The University of Minnesota Wilson Library on the West Bank Campus has an extensive collection of aerial photographs generally dating back to the 1930s. MDNR also has a set of infrared aerial photographs taken in 1992 which cover the entire state. These photographs are available for inspection in MDNR's library in St. Paul. Your county Agricultural Stabilization and Conservation Service (ASCS) and SWCD offices are another source of current and historical aerial photographs. These photos are taken yearly at a scale of about one square mile per slide. The slides are generally filed by township, range, and section. A set of aerial photographs spanning several decades should show changes that have occurred within the watershed and highlight drainage features during dry, "normal," and wet conditions. National Wetland Inventory maps may also be useful in this regard (Appendix III).

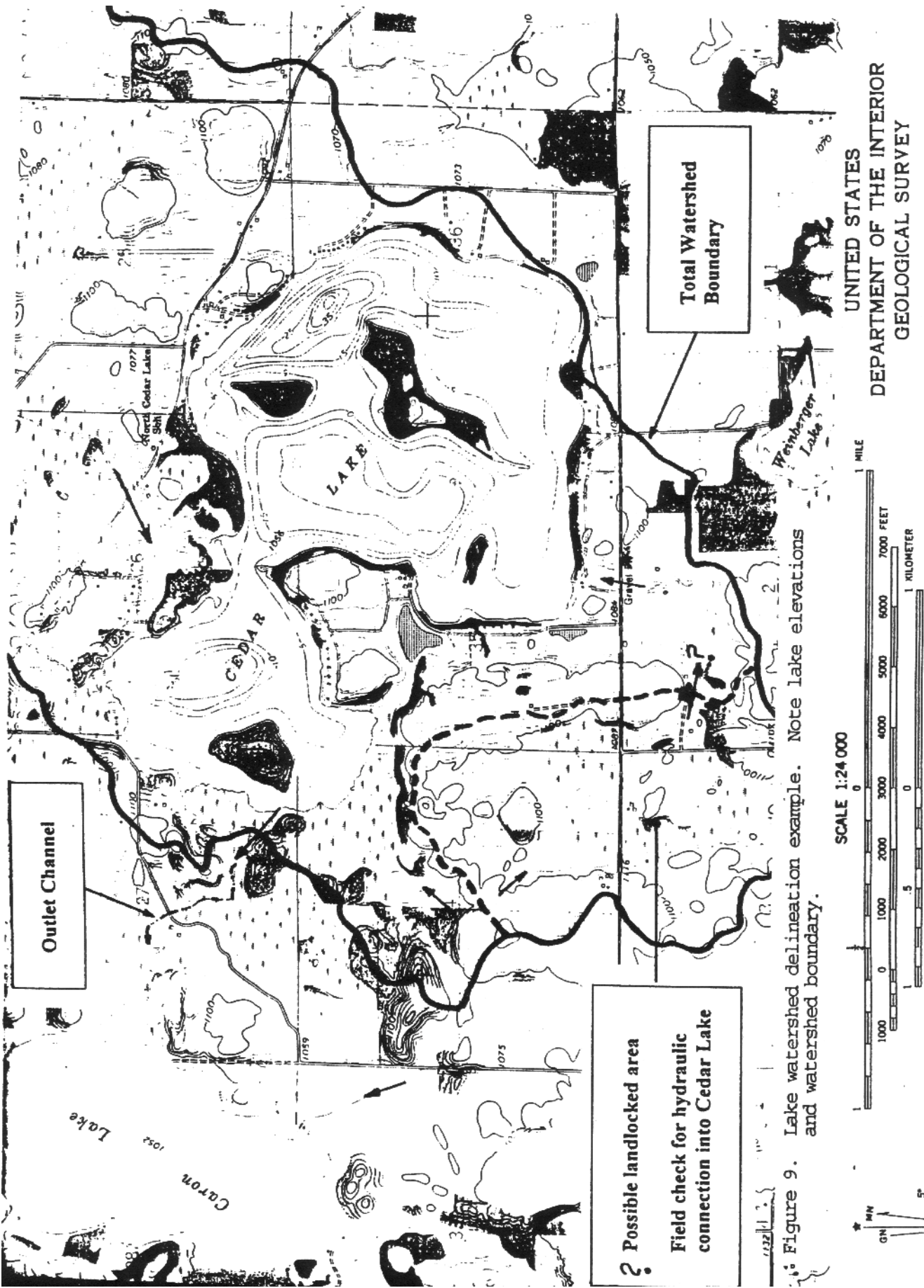

Figure 9. Lake watershed delineation example. Note lake elevations and watershed boundary.

UNITED STATES
 DEPARTMENT OF THE INTERIOR
 GEOLOGICAL SURVEY
 SHIELDSVILLE QUADRANGLE
 MINNESOTA - RICE CO.
 7.5 MINUTE SERIES (TOPOGRAPHIC)

SCALE 1:24,000
 CONTOUR INTERVAL 10 FEET
 NATIONAL GEODETIC VERTICAL DATUM OF 1929

FIGURE 9. Lake watershed delineation example. Note lake elevations and watershed boundary.

Urbanization may alter the watershed boundaries and may not be reflected on USGS topographic maps. Storm sewer and/or drainage maps should be available from the city engineer. As land is developed, drainage will generally continue to follow the existing land contours, but this is not always the case. It is best to check with the city or county engineer to confirm drainage patterns.

A field inspection (ground truthing) may be the only means to accurately determine watershed boundaries in questionable areas. First check for culverts under roads at apparent low spots. Following heavy rains, check for flowing water and note the direction of flow on your map. The field inspection may determine that some ponds and depressions have no outlet. Other wetlands may only discharge water during periods of heavy rainfall, sometimes only every 10 years or longer. Long-time land owners will likely know if water has ever flowed out of a particular pond or wetland on their land, and approximately how often.

Once the overall watershed boundary has been delineated, the next step is to identify all tributary streams and locate where they inlet into the lake. At first, this step can be a tabletop exercise by locating streams on topographic maps or aerial photographs. Conducting a field inspection of the entire watershed provides far greater benefit. While this may seem like a monumental task, it is manageable for most lakes with the exception of those having very large watersheds. This is an essential step in intermediate or advanced assessments.

During the field inspection, observe each water course from available road crossings, following the streams from the lake to the top of the watershed. Locate all road ditches, tile lines, and other water courses that empty into the stream. Note the direction of flow on the watershed map. Also make note of the land use within the watershed and compare to the land use assessment (see next section). Look for land use practices that may have an impact on water quality and again note these areas on the watershed map. Identify and locate all potential point sources of pollution.

Once all tributaries have been located and identified on the watershed map, conduct additional field inspections during and immediately following heavy rain storms. Observe the runoff from several locations in the watershed; in particular, observe those areas suspected of contributing heavy pollutant loads. Identify areas of significant erosion, either from farm fields, areas under construction, streams or ditches. Collect water samples in clear mason jars from several water courses in the watershed and at different times during and after the storm. Visually compare these samples. Is there a noticeable difference in the amount of sediment from sample to sample? How does the sediment load change during the storm? Do streams with heavy sediment loads discharge directly into the lake or does the sediment settle out in a wetland or holding pond prior to reaching the lake? These steps can be accomplished with minimal equipment, but may yield valuable insight into the effect of the watershed on your lake.

c. Land Use Assessment

Land use assessment is a *way of measuring how land is being used or managed within a given area*. Generally, the area of interest for a lake is the watershed. Land use assessments can look at historical land uses, existing land uses or planned or projected land uses.

Land use assessments *provide important information as to what is happening within the watershed*. Land use assessments also can be used to get a snapshot picture of the activity in the watershed for comparison purposes and for planning purposes. Land use assessment is important in intermediate and advanced assessments.

The *amount of information* on land use or land management is *dependent on the goals of your project* and also on the *available resources* to do the work. Take time to develop specific questions that you need to answer prior to deciding how much information to collect related to land use. Ask what the assessment information will be used for (there is no need to collect data that won't be used). Ask how much detail is necessary to accomplish the goals; more detailed information may be developed in the future if the project moves forward in a stepwise fashion.

Background

Land use characteristics can be broken into two types—"natural" and "cultural." Natural characteristics are innate to the landscape and have been developed through natural processes. *Cultural* characteristics are those which have been applied to the landscape through the activity of humans. Information on both types of characteristics should be collected. Information on the natural characteristics will include the geology, soils, climatic and ecological setting.

Detailed assessments of *natural characteristics* may include looking at such things as topographic relief or slope, natural drainage patterns, wetlands, or natural vegetation (based on presettlement, European immigrant, surveys). Information on natural characteristics can be used to evaluate "capability" or "potential" for land uses. Information on the cultural characteristics will include agriculture, industry, commercial, residential, forestry, transportation, mining, recreation, nature preserves, historical and archaeological sites, etc.

Detailed assessments of *cultural characteristics* may include drainage ditches and tiled areas, irrigated areas, sewered and unsewered areas, etc. They may also include looking at particular management practices within a single land use. For example, it may mean looking at cropping practices for individual fields, clear-cut forested areas, etc. Land use assessments which look at the cultural information over a period of time (years or decades) will begin to develop an idea of patterns of use.

Patterns of use are based on the history of the area, changes in management practices, and use trends. Changes in management practices and use trends can be related to each other, but can also occur separately. Examples would be agriculture to forestry or vice-versa, transportation to recreation as rails-to-trails, or agriculture to residential. Examples in changes in management practices within a use would be a change from dry land agriculture to irrigated agriculture, from forage crops to row crops or from clear-cut forest harvesting to selective tree harvesting. The *ecoregion framework* (as noted previously in the manual) provides one basis for comparing land use characteristics from your lake's watershed to the ecoregion in which it is located.

Data collection methods

The simplest and easiest method that can be used is a *grid method*. This method involves constructing an evenly spaced grid over a map with land based information or over an aerial photo of an area (the watershed). Then look at each square of the grid and determine what the most predominant land use is. By counting up the grids according to land use categories you can determine percentages of uses for your area of interest (watershed). If using several maps or airphotos of different scales, be careful to set up the grids to match the scale to keep the information comparable.

More precise land use assessments can be performed by measuring areas on maps or airphotos according to use categories by use of the *polygon method*. This type of assessment is most efficiently done by use of computer technology and requires a certain level of expertise. In this method, each parcel or field in a specific use is delineated and forms a polygon. Polygons can be assigned a use category and areas of individual polygons computed. *Percentages of use* can be determined by summing areas in each category and comparing to the sum of each area to the total area of interest. Percentages of uses computed through this method will be more precise in comparison to the grid method but, as mentioned earlier, the level of precision and accuracy required is dependent on the goals of the program and what the information will be used for.

In the above procedures you have calculated percentages of uses for the area of interest (the watershed). Knowing the percentage of uses within the watershed is essential for lake water quality modeling used in inter-mediate or advanced assessments.

It is also important to get a view of where land uses or activities occur within the watershed, i.e., where, in relation to the lake or contributing streams, do uses occur. Therefore, it is useful to do the land use assessment not only to determine the areas and percentages of land uses within the watershed but also to create a picture of where different land uses occur within the watershed.

Obtaining land based information

Maps or aerial photos are a likely source of information. Several sources for this information are as follows: 1) Local SWCD or SCS offices are likely to have soils maps and soils related information, as well as airphotos for the county; USGS topographic maps; particular study information; and information regarding particular practices employed by landowners which may be helpful. Staff of these offices may provide assistance in carrying out your lake related projects and will be important to include when developing your lake management plan, 2) A map of the land use plan may be available from the local planning and zoning authority. These offices may assist in outlining the requirements in place and the tools available through planning and zoning, 3) The Land Management Information Center (LMIC), in the Minnesota State Planning Agency, may have already done some of the work for you. LMIC has a variety of land based information and performs some selected analyses on it. Information is available (for a fee) in the form of printed maps or may be obtained as computer data files. Some of the data available includes: land use/ land cover, digitized lakes and wetlands, soils, and some geologic data sets, 4) The Minnesota Geologic Survey (MGS) has geologic information based at various scales representing statewide, regional, county, or local geologic conditions. Detailed information is not available for all areas within the state, 5) Federal and state agencies may have land based information particular to their mission or focus or developed through specific studies or projects, or 6) Nonprofit groups such as environmental or conservation groups may have local management projects of interest to your lake project.

As you move into a project for your lake it may be worthwhile to contact representatives from all of the above groups not only to obtain their information, but to develop partnerships for future work.

Field verification of data

As information is compiled, you should make note of the date of the information base or its revision date. You should then ask yourself if this type of information is likely to change quickly (annually, biannually) or if this type of information will change slowly (decades, centuries or longer). If you are working with an information base which changes quickly you will probably need verification of the data. This will mean “walking the watershed” to physically observe what is currently taking place and noting changes. This is essential in an advanced assessment.

d. Shoreland Development

Shoreland development directly affects the water quality, uses, and aesthetic values of a lake. Degraded property values, polluted lakes and groundwater, flood damages, and increased public service costs result when shortsighted thinking and improperly administered land use controls place immediate profits above long-term public benefits.

Background

In 1969, the Minnesota Legislature recognized the important value of lands adjacent to the state’s water resources by establishing the Shoreland Management Program. This program provides for orderly development of shoreland, while protecting lakes and rivers from pollution. The intent of this program is to encourage development of our shorelands to minimize water quality impacts and preserve the natural environmental and economic values.

Minimum statewide standards were updated in 1989. Local units of government then adopt these or stricter standards in the form of local zoning or land use ordinances. The standards affect land above the ordinary high water level within 1000 feet of all lakes greater than 25 acres (10 acres in municipalities) and land within 300 feet of rivers with a drainage area two square miles or greater. The revised rules provide increased protection for areas on steep slopes and near the shoreline and bluff; require upgrading of sewage treatment systems; and establish guidelines for planned unit developments.

A basic lake classification system was developed so that the appropriate development standards could be applied. These standards set guidelines regarding minimum lot size and width, structure setbacks from waters and bluffs, sanitary requirements, subdivisions, shoreland alterations, and uses along the lake. Based on the classification criteria, lakes were classed as Natural Environment (NE), Recreational Development (RD), or General Development (GD).

Local units of government may choose to control shoreland development on additional or smaller waters or may create additional classifications to protect these waters. Always check with your local unit of government zoning office to verify the exact classification and local requirements.

As of the early 1990s, about 150 local units of government have amended their ordinances to meet the current minimum standards. Approximately 100 more are in the process of amending their ordinances. Once a city or county adopts an ordinance, the state’s role becomes largely advisory.

The Minnesota Lakeshore Development Study, conducted by the University of Minnesota in 1967, surveyed over 1900 lakes. The study included all lakes which were greater than 145 acres, outside of municipalities, and not completely in government ownership. Data was collected on the number of seasonal and permanent lakeshore homes within a 40 acre parcel or government lot adjacent to a lake, shore length, dominant shore-area soils and vegetation, and indexes of density. Additional information was collected from a 20 percent sample of lakeshore homes about the value of land and buildings, use of shoreland water, and cultural attitudes.

The 1982 MDNR Shoreland Study updated and expanded the 1967 study to include a breakdown of seasonal and permanent homes having lake frontage and those without frontage but within a lakeshore 40 acre parcel. The percentage of change in development from 1967 to 1982 was calculated for each lake and county. Lakeshore development was then compared by shoreland classifications, fish ecological classes, lake sizes, and vegetation soil characteristics. A development indicator for each lake was measured by the average density of dwellings per mile of shore and per water surface acreage. Data was also collected on the percentage of public ownership, number of beach miles, and number of resorts.

Getting involved and obtaining data

Through programs such as local water planning or voluntary lake monitoring, you can educate yourself and others to the principles of sound water management. Become familiar with the requirements and goals of the local ordinance and comprehensive water plan so that you act responsibly in developing your own land. Give testimony and support for good decision making at public hearings which affect your lake and watershed. Being a good steward by using best management practices on your land serves as an example to fellow landowners.

Obtaining data about shoreland development on your lake aids in analyzing trends of development and predicting future scenarios. Patterns of development may suggest planning strategies and ordinance modifications that can better preserve your lake and watershed in the future. Gathering data on shoreland development can be done in an intermediate assessment.

Historic development information for individual lakes may be obtained from MDNR Division of Waters, Land Use Unit at (612) 296-4800. More current information on development around your lake may be obtained from your county assessor. MDNR Section of Fisheries reports may also include counts of lakeshore dwellings that are obtained during fish surveys. An example of shoreline development data is shown in Table 3.

By comparing the information on densities with information about the resource, it is possible to identify the type of lake which may attract the most development. The ratio of seasonal vs. permanent homes around a lake and their rate of conversion has substantial impacts on the local economy, tax base, and demand for services. Setback and lot size requirements cannot always be met when homes and sewage treatment systems are increased during conversion from seasonal to permanent. Factors such as soil types, vegetative cover, on-shore land slope, off-shore lake bed slope and ecological classification can be used as indicators of the suitability of the shoreland areas for future development.

Once shoreline development information has been collected and analyzed, concerned citizens should work with local zoning officials to assess the potential and impact of future lakeshore development. Are there thresholds beyond which development will adversely impact shoreland and watershed resources? What is the vision of development by the landowners and the public? What uses are compatible with lake management objectives? How many buildable lots could potentially be developed if subdivision occurs under the ordinance provisions? The amount of development can have very different impacts depending on the amount of water surface space and shoreline available to potential users.

Resource management plans that are based on sound data analysis ensure steady economic growth in stride with increased user demands, while still preventing resource deterioration.

Table 3. Shoreland development data.

	1967	1982	1993		
			with buildings	without buildings	total
Seasonal homes	423	596			
Seasonal properties			440	299	739
Permanent homes	42	122			
Residential homesteaded properties			144	57	201
Residential non-homesteaded properties			8	1	9
Subtotal	465	718	592	357	949
Resorts	13	8			
Resorts - homesteaded			8	2	10
Resorts - non-homesteaded			4	6	10
Commercial/Industrial			1	0	1
Farm					
Agriculture					
Timber					
Utilities					
Public Properties			12	21	33
Total	478	726	617	386	1003

1967 data: Number of structures in a 40-acre parcel or government lot bordering a lake. If county assessors' records were used, homesteaded structures were considered permanent and structures designated as recreational or non-homesteaded were considered seasonal. Source: Minnesota Lakeshore Development Study, University of Minnesota, 1970.

1982 data: Number of structures in a 40-acre parcel or government lot bordering a lake. Homesteaded structures were considered permanent, and non-homesteaded structure were considered seasonal. Source: Minnesota Shoreland Study, Department of Natural Resources, 1984.

1993 data: Number of properties with lake frontage. Source: Crow Wing County Assessor's Office

e. Tributary Monitoring and Mass-Balance Considerations.

After defining the tributaries or streams within the lake's contributing watershed, a stream monitoring program can be set up to determine the quantity and quality of water entering the lake. Stream monitoring programs may range from calculating nutrient loads entering the lake to determining the general health of the stream by monitoring its benthic macroinvertebrate population. Defining the purpose for the monitoring is essential prior to initiating a monitoring program. Tributary monitoring is conducted as a part of an advanced assessment.

Stream sampling requires a comprehensive (in time and space) monitoring program and, at a minimum, a record of flow rate at the time of sampling (a continuous or daily flow record is preferable). There are typically five reasons or strategies for conducting stream monitoring (Whitfield, 1988; Osgood and Oberts, 1989). These strategies are summarized as follows:

Trend monitoring refers to both the assessment of short-term trends related to impacts resulting from land changes, and the assessment of long-term trends related to meteorologic cycles. *Compliance monitoring* makes sure that the stream meets specific set goals or standards. *Mass transport monitoring* assesses the stream's nutrient (or other pollutant) load to the lake. *Environmental impact monitoring* assesses impacts to the stream. *Surveillance monitoring* provides an inexpensive quick sampling of an assortment of sites over a broad area.

For lake and watershed assessment purposes, "mass transport monitoring" is generally the most useful monitoring to undertake. A well-designed mass transport monitoring program will allow you to calculate a "mass-balance" (phosphorus for example), for your lake. An accurate phosphorus mass-balance provides the basis for making decisions on how and where to reduce phosphorus loading to the lake and a basis for predicting the response of the lake to changes in loading. Before we describe methods for measuring stream flow and concentration, a brief review of important concepts may be helpful.

Loadings most accurately express the relative impacts of various watershed sources on lake water quality (Moore and Thornton, 1988). For example, a stream with high phosphorus concentration may not necessarily be an important source to the lake, if the stream has a very low flow and, therefore, contributes a relatively low annual loading. Loadings change in response to season, storm events, upstream point and nonpoint sources, and land use changes.

The first step in lake modeling (mass balance calculation) is to establish a water balance for the lake. Flows carry pollutants into and out of lakes, and analysis of lake eutrophication and other water quality problems cannot be conducted without a quantitative understanding of water flow through the lake (Moore and Thornton, 1988). The basic water balance equation considers the following flow terms, typically in units of acre-feet per year:

$$\text{INFLOW} + \text{PRECIPITATION} = \text{OUTFLOW} + \text{EVAPORATION} + \text{CHANGE IN STORAGE}$$

Water budget concepts are illustrated as follows:

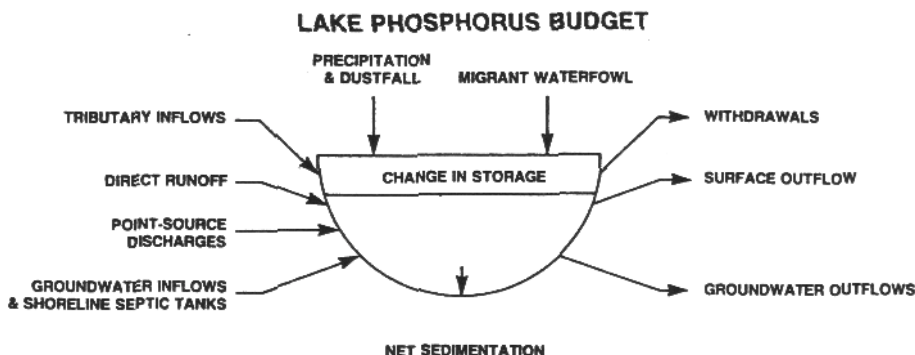

The lake *phosphorus budget* serves as a basis for evaluating the condition of a lake and determining appropriate strategies for reducing the amount of phosphorus which enters the lake. The following terms are evaluated and typically expressed in units of pounds or kilograms per year (Moore and Thornton, 1988):

$$\text{INFLOW LOADING} = \text{OUTFLOW LOADING} + \text{NET SEDIMENTATION} + \text{CHANGE IN STORAGE}$$

This equation summarizes fundamental cause and effect relationships linking watersheds, lake processes, and water quality responses and can be depicted as follows (Moore and Thornton, 1988):

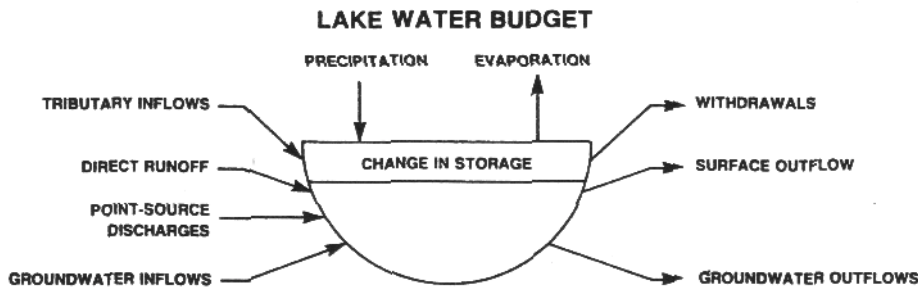

The extent and intensity of monitoring inflows will vary. For example, stream loadings are typically the largest source of phosphorus to the lake and are estimated by monitoring stream flow and phosphorus concentrations over at least an annual period. In contrast, precipitation loading is usually relatively small and can be estimated from literature values. Special studies may be required to estimate groundwater input terms, if groundwater is felt to be a major source and finances allow for the studies.

As previously noted, stream monitoring and mass-balance calculations require intensive monitoring and may be quite expensive. It may be wise to seek the advice of MPCA Water Quality Division, MDNR Division of Waters, county environmental services, or watershed district staff prior to conducting a stream water quality monitoring program.

Stream velocity and discharge

A lake may have several inlets, including storm sewer outlets, small streams, agricultural and roadway ditches and major rivers. It may be beyond the available resources to monitor all streams. Representative streams (those likely to contribute 75 percent or more of the flow to the lake) should be selected based on the size and characteristics of their subwatershed in relation to the overall watershed of the lake. Results from the monitoring effort can be extrapolated over the entire watershed based on watershed areas, if the subwatershed areas are similar in terms of land use, etc.

Flow rate, or *discharge*, is the amount of water passing a specific point in the stream for a given period of time, generally specified in gallons per minute (gpm) or cubic feet per seconds (cfs). (Note: 1 cfs = 448.8 gpm) The discharge in a stream will be highly variable; the flow rate in a smaller stream will even fluctuate greatly from hour to hour immediately following a heavy rainstorm.

In order to calculate discharge, you need to know the cross-sectional area of the stream and the velocity of the point of measurement. Determining the *velocity* of the flowing water is the most difficult task.

An easy, although very crude, way to determine stream velocity is by timing how long it takes for an object (something which floats submerged like an apple or an orange) to float a known distance downstream (sometimes referred to as the Embury Float Method). It is best to select a straight section of the stream with little turbulence in order to ensure the object floats in a straight line, making the distance of travel easily determinable. The time and distance measurements should be repeated at least twice and the average of the two determined. The surface velocity can then be converted to a mean water column velocity by multiplying by 0.8 for a rough stream bottom (gravel or rock) or 0.9 for a smooth bottom (sand or mud) (Nielsen and Johnson, 1983).

The cross-sectional area of a stream is the area of the vertical cross section, perpendicular to flow, containing water. The area is computed from the width times the mean depth. Mean depth is calculated by measuring depth at 0.5 to 1 meter intervals across a cross section of the stream and dividing by the number of measurements (Nielsen and Johnson, 1983).

The stream's *discharge* can be estimated by selecting a reasonably straight section of stream where the flow and velocity is relatively obstruction free, and then dividing that cross-section into three separate sections. Within each section, measure the width (W, feet), mean depth (D, feet), and time (T, seconds) it takes a float to travel a given distance (L, feet). Discharge (Q) in each section is estimated, where (A) is a coefficient which converts the surface velocity to mean velocity. The full equation used to calculate discharge is shown below. Discharge is equal to the sum of the discharge for the three sections (Nielsen and Johnson, 1983).

$$Q = \frac{W \times D \times A \times L}{T}$$

Lake water quality modeling in advanced assessments often requires *frequent* (e.g. daily flows) and *accurate* stream flow data. One approach is to install a gauge in order to record the fluctuating level of the stream at the sampling

site. (A simple gauge would be a yard stick taped to a fence post, which is then stuck in the stream channel.) A rating curve can be developed after three to five flow measurements have been obtained at varying flow rates (e.g. high and low flows). On graph paper, plot the water level on the vertical axis for each of the measured flow rates on the horizontal axis. Complete the rating curve with a “best fit” (regression) smooth line. Once the rating curve is established, subsequent discharge values can be obtained by using the recorded water level and the plotted rating curve. It will no longer be necessary to measure flow with every water quality sample; only infrequent measurements to check the rating curve will be needed. This technique works well on stream segments with a welldefined channel or constriction (e.g. bridge or culvert) and where there is an adequate gradient so that the water flows in only one direction (i.e. flow direction not related to volume of stream flow).

Timing the speed of a floating object is a crude means to determine velocity. This method can be as much as 50 percent off the actual flow. Lake water quality modeling efforts that require accurate stream flow data will not rely on this method. Special equipment is available to accurately measure flow (e.g. continuous flow recorders and flumes), however, obtaining this equipment is likely beyond the capabilities of most lake associations. It is highly recommended that you seek advice from technical experts in MPCA Water Quality Division or MDNR Division of Waters (Appendix III) prior to undertaking extensive stream flow and loading studies.

Stream pollutant concentration and load estimation

The primary motive behind sampling a lake’s tributaries is to determine what nutrients (or other pollutants) are entering the lake, and at what rates (i.e. loading estimates). An annual load of a stream relates to the total weight or mass of pollutant the stream discharges yearly to a receiving waterbody. *Loading estimates* are best obtained through a combination of storm-based (event) sample collection and some base-flow (routine) sample collection. For nonpoint source pollutant estimation, the majority of the sample effort (e.g. 75 percent or more) should be directed toward the storm-based sampling. This is usually when the majority of the pollutant loading can be expected. Walker (1986) provides further details on sample frequency and emphasis (summarized in Table 11, Appendix II).

Grab samples and flow measurements should be made for each sample event. For storm-based sampling it is desirable to make composite water samples based on the amount of flow which passes the sample site during the event being monitored. This can be quite time consuming and, thus, automated equipment is frequently used for this purpose.

Pollutant concentration and the corresponding flow allow for the calculation of flow-weighted mean concentrations. This is preferable to an arithmetic mean concentration which is unrelated to flow. The difference between the two is that the flow-weighted mean relates the specific sampling date nutrient concentrations to measured flow, while a mean concentration unrelated to flow is merely a grab sample, and fails to describe how that concentration may be associated to the amount of water passing the sampling location (i.e. the more precipitation, the greater the watershed runoff and eventual flow, and the greater the total phosphorus concentration of the grab sample). Therefore, for nonpoint sources, a flow-weighted mean provides a better description of the actual nutrient concentration in the stream.

An example of stream monitoring data and its organization is shown in Table 4. In this typical nonpoint source example, total phosphorus (TP), total suspended solids (TSS), and flow (Q) are measured on each sample date. In this example, it is evident that high TP and high TSS concentrations are associated with high flows (i.e. most pollutant loadings are associated with storms and high flows). This is common in streams which receive extensive runoff from cultivated lands, feedlots, or highly urbanized areas. Based on these six sample events, the arithmetic mean TP concentration is 292 µg/L. However, the flow-weighted mean concentration ($\sum \text{sample TP} \times \text{flow} \div \text{total flow}$) is 623 µg/L. Thus, if the significance of stream flow on concentration is not considered, the resulting mean concentration of the stream will be underestimated. Subsequently, the TP loading from this stream to the lake would be underestimated and an inaccurate mass-balance would result. (Note: Table 4 is for example purposes only. Typically, we would be estimating an annual loading from the stream based on sample data collected throughout the year.)

Additional water quality samples (preferably storm-based) and a daily record of flow would be required to improve on our estimate of loading for this stream. If daily flow data are available, then computerized data reduction software such as the U.S. Army Corps of Engineers’ FLUX may be used. FLUX is an interactive program for estimating pollutant loadings or mass discharge passing a tributary or outflow monitoring station over a given period (Walker, 1986). Measuring flow on a less frequent basis (e.g. weekly or at each sample event) can produce errors of 20 percent or much more, especially in small streams which can be very “flashy” (respond quickly to precipitation events). Additional considerations for stream sampling are provided in Wilson and Schuler (1991).

Table 4. Stream water quality data example.

Date	Flow (cfs)	TP ($\mu\text{g/L}$)	TSS (mg/L)	Flow x TP
27-Feb-92	11.8	780	45	9,204
06-Mar-92	2.0	570	220	1,140
22-Apr-92	0.3	40	5	12
16-May-92	0.1	40	5	4
16-Jun-92	3.2	240	54	768
17-Jun-92	0.4	80	9	32
Total Q = 17.9		$\bar{x} = 292$	$\bar{x} = 56.3$	Total = 11,160
Flow weighted mean: TP = 623 $\mu\text{g/L}$ TSS = 64.7 mg/L				

Proper data management can simplify these calculations. With proper management, e.g., use of PCs and electronic data files, not only will the data be more understandable and easily manipulated, but it can allow data to be easily transferred into STORET, U.S. EPA's water quality data bank, as well as incorporated into FLUX and other data reduction software. The best data management tool is a personal computer. A spreadsheet program such as Lotus 1-2-3 and database software such as PARADOX can be set up similar to that in Table 4, with sample date, flow, and nutrient concentrations arranged in columns from left to right. This way, each sampling dates measurements and calculations can be easily read and manipulated. The spreadsheet can also be expanded to include columns such as [flow * TP] (far right column in Table 4), to help with calculations and simplify the data management process as much as possible. If a personal computer is unavailable, data tables should still be set up in a similar fashion so data can be easily read, understood, and transferred.

Benthic macroinvertebrate monitoring

The water quality of a stream also can be monitored by an investigation of its benthic macroinvertebrate community. The primary purpose for this type of monitoring is to evaluate the health of the stream, though, rather than its impact on a lake. This might be done in an advanced assessment, for example, where the health of an individual stream may be a concern. Benthic macroinvertebrates are animals that live in or around the stream bottom, lack a backbone and can be seen with the naked eye. In freshwater streams, the benthic macroinvertebrates are mostly aquatic insects in their immature forms, but also include clams, crayfish, snails, and aquatic worms. By simply looking at the diversity and relative abundance of benthic invertebrates present in the stream, one can get a comparative picture of the health of a stream ecosystem (Illinois Department of Energy and Natural Resources, 1990).

To conduct macroinvertebrate monitoring, an identification key, a net, a pan, tweezers, magnifying glass, and ethylalcohol filled jars (if sample is going to be preserved) are needed. Water samples are best collected in riffle areas (places where the water flows swiftly over rocks). A D-frame kick net can be used to collect the organisms. The materials needed to construct a homemade kick net (as shown in Fig. 10) include pieces of nylon screening, strips of heavy canvas, and a six foot long broom handle. A step by step description on the construction of the kick net is provided in Fig. 10.

To collect samples, the net should be placed firmly on the stream bottom, making sure the net is flowing downstream. By disrupting or kicking the stream bottom or rocks upstream of the net, the invertebrates will be swept into the net by the flowing water. To remove the net, use a scooping motion to lift it up and carry it to shore.

Once on shore the contents of the net can be placed in the pan and separated with the tweezers in order to better identify the organisms. If the sample is to be analyzed at a laboratory, it should be placed in a jar with preservative before delivery.

Benthic macroinvertebrates are classified according to international rules of nomenclature starting at the largest classification (Kingdom, Animalia) and proceeding to the lowest common classification (Species) as follows: Kingdom_Phylum_Class_Order_Family_Genus_Species (Davis et al., 1992). The most commonly used classification level for these water quality assessments are Class and Order. The majority of the Environmental Protection Agency's Rapid Bioassessment Protocols (Plafkin et al., 1989) use Class and Order as well.

After the organisms are identified, assessments can start to be made as to the quality of the stream. Table 4 (Appendix II) lists different taxa and their pollution tolerance.

Chapter IV

Ancillary Information

In addition to obtaining physical, chemical and biological data on the lake and its watershed, it is also helpful to obtain some cultural, historical and climatic information. The information summarized in this chapter will prove useful as you develop your lake management plan.

a. House-to-House Septic System Survey

A survey of the wastewater handling practices of lakeshore residents can provide useful information for the lake management plan. Prior to conducting a survey, it is advisable to check with your local unit of government, e.g. city, township, or county environmental services staff to see if the information already exists. A house-to-house septic system survey should be included in an intermediate level of assessment.

Table 5 is a suggested survey form. The form is designed not as a regulatory tool, but rather to provide the association with information on the types of systems in use around the lake, age of system, frequency of use, and frequency of maintenance (pumping).

The survey forms should be distributed to each property owner. Delivery in person is preferable to mailing (the survey return rate is generally greater with the personal contact). One method may be to enlist pairs of volunteers from several locations around the lake and request that they handle their “neighborhood” or “beach area.”

An analyses of the data from the survey forms will provide the association with an impression of the overall knowledge of the lakeshore residents on their systems and maintenance. Table 6 is a suggested way to summarize the data. From this summary it is easy to graphically present data, e.g., pie charts, at organizational meetings, or in a newsletter. This information will help the association to determine if additional education of members is needed or whether outside assistance from the county or state may be needed to improve wastewater handling practices around the lake.

Results from the survey may help determine the need for individual septic system inspections. These inspections can be done as a part of an advanced assessment. Individual inspections will most likely be conducted by local units of government officials (e.g., county or township). Work closely with the local units to determine follow-up action.

b. Lake and Watershed History

The lake association is encouraged to research their lake and watershed and to compile a brief, written historical summary of significant events, alterations occurring in the watershed and along the lake’s shoreline, and other important information. The purpose of this is to begin a written summary of the lake which may help to explain current and future water quality problems. This should be done as a part of an intermediate assessment. Some suggestions are as follows:

5. Examples of summarizing your chronology are included in Table 7. Note in both examples that each lake has along history of man-made impacts in the lake or its watershed. These historical impacts influence the present day water quality of the lake and also the ability of the lake to recover from these impacts.

Table 7. Lake history example.

TABLE 2. HISTORICAL BACKGROUND: BIG KANDIYOHI LAKE WATERSHED

1895	State Capital Lands Ditch #1, constructed to improve natural drainage, provided a defined waterway from Wagonga to Fanny to Big Kandiyohei to Lillian to Dog Lake.
1908	Judicial Ditch (J.D.) #1 completely changes natural drainage by blocking the outlet of Wagonga Lake to Fanny Lake. Wagonga was connected to Little Kandiyohei ditch, then passed to Big Kandiyohei Lake to Lake Lillian, effectively diverting flow of South Fork of Crow River from Fanny, Big Kandiyohei and Lillian Lakes. [Reduced watershed of Big Kandiyohei Lake from 15:1 (watershed to surface area) to a ratio of less than 3:1.]
1920s	Levels of Big Kandiyohei Lake began receding. Attempts were made to construct an auxiliary ditch from J.D. #1 to Big Kandiyohei Lake. Temporary improvement in lake level was noted.
1931	A secondary sewage treatment plant was constructed at Willmar. Effluent discharged to County Ditch 23A, thence to Wagonga Lake.
1938	Big Kandiyohei Lake has maximum depth of four feet as a result of drought.
1941	Minnesota Department of Natural Resources (MDNR) survey shows water levels of Big Kandiyohei Lake about ten feet below normal.
1945-55	Wet years filled Big Kandiyohei Lake and also flooded some surrounding land.
1950s	J.D. # 1 was deepened to alleviate flooding, making it difficult to divert water from J.D. #1 to Big Kandiyohei Lake.
1953	Lake level up and some problems with flooding of adjacent land.
1957	Ditch between J.D. #1 and Big Kandiyohei Lake constructed, but does not work.
1967	Legislature allocates money to construct an overland ditch from Wagonga Lake to Big Kandiyohei Lake.
1969	Toxic algae blooms noted on Big Kandiyohei Lake. Diversion from overland ditch halted.
1978	Study of alternatives for augmenting water levels by temporarily pumping water (by MDNR) from J.D. #1 to Big Kandiyohei Lake.
1981	City of Willmar diverts wastewater discharge from Wagonga Lake to Hawk Creek, which flows away from Big Kandiyohei Lake.

TROUT LAKE HISTORICAL SUMMARY

1870s	Logging of forested areas near the watershed occurred. No significant logging has occurred since that time.
1900	An 80-acre farm on the west side of the lake was operated by a man named Eastwood.
1907	Discharge of fine ore tailings into the lake from the Trout Lake concentrator began. The concentrator was on the eastern shore of Trout Lake. The tailings filled an entire bay that was originally 3/4 mile long and a mile wide at its mouth. The average depth of the bay was 50 feet. Eventually, fine red tailings covered the entire lake bottom.
1910	City of Coleraine was built. Raw sewage discharge into the lake begins. Eventually, city of Bovey discharged wastewater into the lake.
1940s	(Previous) Dumping of ore tailings into the lake discontinues.
1940s	Trout species disappear from the lake. A 1946 MDNR report finds that trout disappeared from all lakes in Itasca County at that time.
1950s	Some beaches on the lake closed by the Minnesota Department of Health because of high levels of <i>E. coli</i> .
1957	Primary sewage treatment plant built eliminating raw sewage discharge into the lake. Plant did not eliminate phosphates in the processing and the treated wastewater with the phosphates was discharged directly into the lake.
1960s	Beaches reopened.
1970s-80	Raw sewage is dumped into the lake at times of heavy rainfall because of problems with rain water infiltration into sewer lines in both Bovey and Coleraine.
1969, 71, 73	Three years of major fish kills in Trout Lake. Village crews used a front-end loader to haul away 12 truckloads of dead fish in either the 1971 or the 1973 kill.
1982-87	Beaches on lake closed because of heavy algae growth. Residents report algae and weeds becoming excessive. Lake use drops off.
1987	Summer of 1987 reported as one of the worst for weeds and algae growth by residents. New sewage treatment plant built. There should no longer be any wastewater discharged into the lake unless the unsolved infiltration problem is a factor.
1987	August, USX land holdings around Trout Lake sold to a Twin Cities developer.

c. Lake Use

Minnesota's lakes are used by its citizens in a number of different ways. The most prominent uses include drinking water, industrial uses (water appropriation and discharge), agricultural irrigation, catch basins for runoff, and outdoor recreation. Knowing the type and extent of these uses is critical to evaluating lake condition. This can be done as a part of a basic assessment.

Nearly all municipal, industrial, and agricultural water appropriations and discharges are covered under permits issued by the MPCA or MDNR. Contacting these agencies and reviewing applicable permits should create a reasonable picture of the extent of these uses. Investigation of the immediate watershed of the lake may uncover situations that should require permits but are not currently under formal review. These should be reported to the appropriate public agency.

The number of residences, year-round and seasonal, businesses and other developments should be known for the lake's shoreline and, if possible, its immediate watershed. Visual observation is the primary tool for data collection, although county tax records and plat books may prove helpful. The percentage of developed shoreline and public ownership can be useful in determining trends. The percentage of immediate watershed in residential, commercial, industrial, agricultural, and forestry use is also of value.

Recreational use of the lake can be more difficult to ascertain. While the basic tool for data collection is visual observation, the key to sound information is establishing appropriate sampling periods. Counts can include vehicles in parking lots, boats or personal watercraft on the water or at moorings, ice fishing houses, snowmobiles, all terrain vehicles, and individual people at beaches and parks. Determining what to count, and when, is critical to determining current use levels and developing trends. This step can be incorporated in an intermediate assessment.

MDNR fisheries personnel have established guidelines and methods for analysis of lake recreation uses. The best approach is to meet with the local area fisheries manager to determine what information is currently available and how it can be best augmented. Guidelines can be established for additional data collection and assistance provided for data analysis.

d. Climate Data

Precipitation data is the most important climatological data needed for lake management. Precipitation is the primary factor affecting lake levels which, in turn, can affect the recreational use of a lake and the water quality of the lake. Precipitation information is also required for any type of hydrologic or water quality modeling. Much historic data exists, and an extensive ongoing gauging program is operating throughout the state.

While average annual or monthly precipitation information is available statewide, the variability of precipitation from year to year is generally of more interest for lake management. The effect of varying climate conditions on lake level and water quality parameters can be assessed for "normal" years, as well as very dry or very wet conditions.

First, check your county water plan for available climate data. This plan will likely contain historic climate data and the location of existing precipitation gauging stations. A summary of historic monthly precipitation data (as opposed to daily data) is generally sufficient for most lake management purposes.

Rainfall is highly variable from one location to another. An extensive gauge network in Minnesota is coordinated by MDNR State Climatologist in order to obtain an accurate record of precipitation. This network consists of approximately 1,300 active readers. Most county SWCDs coordinate readers for their county and forward the information to the State Climatologist. There is a good chance a reader is located in the vicinity of your lake.

The state climatologist prepares a yearly summary of precipitation data for each county. The recorded daily rainfall amounts are summed to give monthly totals for each reader. Average monthly precipitation amounts for the county, as well as yearly totals for each reader, are also provided. These summaries should be available from your county SWCD office. An example is shown in Table 5 (Appendix 11).

Your lake association may want specific precipitation information for your lake. Two or more readers may be needed on larger lakes to obtain average rainfall amounts over the entire lake. Rainfall should be measured and recorded on a daily basis, at generally the same time of day (e.g., 7 a.m.). If you want to become part of the county network of readers, contact your SWCD office. Establishing rain gauges for your lake can be included in basic or intermediate assessments.

e. Economic Significance of Lakes and Reservoirs

Defining the economic significance of lakes to the local and state economy is an important, but often overlooked, part of lake and watershed assessments. Lakes cannot take care of themselves with the intensive pressures now placed on them. While they can be degraded over short time periods, there are very limited public resources that are available to “restore” degraded lakes. Currently in Minnesota, the demand greatly exceeds state and federal program dollars. Therefore, the prudent and reasonable alternative is to wisely manage our lake resources now. Determining the economic significance of your lake is a part of an advanced assessment.

We know that, in our own lives, maintaining our health is everything. It is the same in a lake’s life—environmental health is crucial and, when a lake’s health becomes degraded, it can be extremely difficult to regain. Additionally, lakes have values beyond realms typically quantified by accountants and county assessors as in dollars and possessions. In this sense, determining the economic significance of your lake may be difficult to do, but some ideas which have been used elsewhere in Minnesota will be presented to assist you in this task.

Decision-makers (and some riparian property owners) must become aware that lakes are complex ecosystems that are vulnerable, that can be degraded in many ways, and often without anyone knowing it unless monitoring is done. They must also realize that the entire community (plus visitors and tourists) lose when the resource is degraded. Decision-makers must also realize that the resource is an important component of the long-term economic vitality and stability of the area. Riparian property owners need to know that the quality of the lake has a direct impact upon the value of their property. Additionally, this information must be used in a constructive manner to get all watershed residents working together to improve the lake resource—and not to divide the groups.

Local units of government and associated decision-makers are expected to routinely determine the reasonableness of proposals that may affect lake water quality. Due consideration of cost-benefits are difficult to achieve, in many instances, because there is little environmental information compiled for such purposes. Assembling an economic summary of the value of the lake to the local economy will help local decision-makers make appropriate decisions regarding lakes and their watersheds, and activities which may affect the long-term health of the lake. It may also help you to communicate your message to all watershed and lake “shareholders.”

Defining an initial starting point (date) to anchor your economic and lake water quality assessments is suggested. This provides a basis for evaluating the cumulative impact which may result from the numerous small impacts (e.g., individual land use changes in the watershed or poor management practices) to the lake which may occur over a 25- or 50-year time frame (what one to two generations of residents may realize). Ideally, you will have good water quality, fishery, and other data for the beginning time frame (1990 for example). All changes occurring since that time must be additive and then assessed against the total lake response over time.

Determining economic impacts must be a collaborative project: county assessors, treasurers and recorders, plus someone who can retrieve data from computer files, can all be helpful. You may also consider requesting countywide summaries from the Department of Trade and Economic Development or your regional development commission. ([The Minnesota Lakes Forum’s first recommendation was to request that state government - “determine the statewide economic significance of lakes to Minnesota.”])

The following approach is summarized from two cases in Minnesota which have been quite instrumental in achieving change (Lake Bemidji and Big Sandy Lake Watershed) and a paper presented by Todd (1990). We are not economists and must defer economic arguments and techniques to those so trained. But, based on previous economic assessments, the following should be considered:

Property Value Impact

Evaluating riparian property values and demographics relative to the remainder of the county is a good starting point. Data gathered at this step will be useful in latter portions of the economic assessment. Relevant information to gather includes the following:

1. Size of the lake. Determine the surface acreage of the lake. Subsequent calculations use surface area as a basis for estimating economic value.
2. Demographics of the lake. This includes a description of the number and type of properties around the lake and the people who live and recreate there.
 - a) Determine the number and type (year-round or seasonal) of residences around the lake and the total number of properties in the county.
 - b) Estimate the number of persons from seasonal cabins, year-round homes and camp sites and the number of people per dwelling to yield an estimate of the number of residents around the lake. The

relative percent of seasonal to permanent residents is important information. These numbers can be compared to the total population of the county or city you are making a comparison with. For example, Aitkin County and Cass County, Minnesota, have more seasonal homes than permanent residences (Todd, 1990).

- c) Determine visitor-years per year to the area. The Minnesota Office of Tourism may be able to help you here, as well as regional development commissions, local chambers of commerce, resort and hotel associations. This information will be used to help assess impact on the local economy.

3. Property values and public revenues. The following should be considered:

- a) What is the county assessor's estimated market value of the riparian property plus buildings?
- b) What are the real estate taxes paid by riparian property areas?
- c) What percent of the county or local unit of government's real estate taxes is paid by riparian landowners?

Local Economic Impact

In this step, information pertaining to the local economy is compiled. Using this and previous information, the share of the total local economy comprised by lake-dependent economic activity may be estimated.

4. Income to the county. The relative amounts of income to the county's economy and jobs derived from service and manufacturing industries, agriculture (livestock versus crops), tourism, forestry and the like should be defined. The county extension office may be of assistance here.
5. Income and jobs generated by the lake. Identify retail and service industries associated directly with the lake resource (e.g. hotels, restaurants, food, bait, sports shops, apparel, vehicles, gasoline/fuel, boat sales and service, docks, cabin/home sales and services, camping, hiking, other recreational activities, and license fees). The seasonal aspects of income need to be considered as well, including fishing, hunting, tourism peaks to the local economies augmenting existing local agricultural and manufacturing bases.
 - a) If exact figures are not available, the number of jobs generated by the lake (direct and indirect impact on employment) may be estimated at 16.5 jobs per thousand acres of surface water, based on Todd (1990).
 - b) Define the direct and indirect lake related incomes. Define the local populations by category as above (e.g. retired, seasonal, and permanent, etc.). Multiply the average income per year for each category to estimate direct incomes.
 - c) Define the indirect incomes by use of county or other multipliers. In Minnesota, this was estimated by Todd (1990), in 1985 dollars (1993 dollars in parentheses), to be: consumer purchases (direct) of \$509 per acre (\$752); direct and indirect impacts on total gross output - \$830 per acre (\$1,226), total value added of \$371 per acre (\$548). (Note: Consumer purchases represent direct impacts of lake-generated incomes. Total gross output combines direct and indirect impacts, using an income multiplier of $830/509 = 1.63$. Total value added would be the gross output net of wages and other expenses.)
 - d) Define tourist expenditures and local income multipliers to tourism expenditures. In Minnesota, the total income multipliers, defined by Larson (1979), ranged between 1.4 and 4.6 with an average multiplier of 2.68 (in 1979).

With this information, comparisons between lake derived jobs and income can be compared to jobs and income from other sources in the county. Results may be expressed in terms of total dollars or percent of the total. For example, "Lake related tourism in County XYZ generates 20 percent of the total income to the county."

Intangibles

This includes two concepts which are hard to quantify—consumer's surplus and option value, but important nonetheless to consider and discuss with the lake association membership. Conservative estimates for each are preferable.

6. Consumer's surplus. Since a great deal of outdoor recreational experience depends upon the perceived quality of the resource, a good resource helps insure pleasurable outings. The economists call this the "consumer's surplus" or willingness to pay an amount over and above the necessary expenditure. For

7. Option value. In a similar manner, the option value, or the amount that individuals are willing to pay to protect the resource for future generations, was defined by Larson (1979). This may be the closest economic category to describe the protective considerations that some families feel about their favorite lake. For the purposes of discussion, a value of \$125 per year per family is advanced. Local groups will have to carefully survey their group to determine this value.

Cost of protection versus restoration

This section makes use of previously acquired information and information on current lake management expenses. Using this information, you will attempt to project the costs of protecting the current condition of the lake versus the costs of restoration at a later date. A variety of considerations can come into play here. Some relevant considerations include the following. The impact of degraded water quality on: the riparian property tax base, tourism in the area (including dollar and job-related impacts), and on intangibles.

8. Management and restoration expenses. The current costs of managing the lake and its watershed should be estimated versus the costs of restoration at a future date, prorated to current dollars. Restoration expenses will be greater, not less, in future years. That likelihood, coupled with the uncertainty of restoration outcome, must be evaluated in current decisions. Conversely, protection measures are much cheaper than restoration alternatives. For example, hiring county staff to educate and insure zoning compliance is extremely inexpensive compared to restoration programs in Minnesota. Hiring staff may amount to \$20,000 to \$75,000 per year, versus restoration expenses of approximately \$300,000 to \$10,000,000 for restoration (plus the county staff then being hired after the damage is done).
 - a) Estimate the amount of dollars directly expended by the association, county and local units of government, and state/federal governments for the lake and watershed management activities (e.g. sampling, lake management plan preparation, zoning education etc.)
 - b) Estimate restoration expenses (benefits). After defining the total number of jobs attributable to the lake via industries and occupations defined in *5 above, crudely estimate the impacts of an improvement to the lake by improved water quality, for example, by increasing estimates by 10 to 25 percent. Then, conversely, estimate the effects of deteriorating water quality on the local economy by subtracting 10 to 25 percent of the jobs. Extrapolate the effects over a period of 25 to 50 years. Also, if the lake degrades, loss of property values are possible, if not likely. Estimate the net loss to the local property tax revenues resulting from 5 percent and 20 percent property value declines. Conversely, estimate the long-term revenues resulting from lake water quality improvement (e.g., 5 percent and 20 percent increases in revenue). Estimates of reduction in tourism expenditures could be made in a similar fashion.

The following worksheet is provided to assist you with your calculations and record keeping as you conduct your economic assessment. The worksheet is not intended to provide all possible calculations or considerations on this topic. For further reading and explanation the following publications are suggested.

Further Reading:

Dziuk, Dr. Harold. 1992. Big Sandy Lake Looking Back, Looking Ahead. Big Sandy Lake Association, Inc., Box 21, McGregor, MN 55760

Larson, Sandra. 1980. Additions and Corrections to the Economic Portions of the Draft Environmental Impact Statement, Bemidji Wastewater Treatment System, Beltrami County, Minnesota. Minnesota Pollution Control Agency. St. Paul, MN 42 pp.

Minnesota Lakes Forum. 1992. Managing Minnesota's Lakes. A Report of the Minnesota Lake Management Forum. Funding provided by the Blandin Foundation, Grand Rapids, MN.

Todd, H. 1990. Importance of lakes to Minnesota's economy. pp 4-6 in LakeLine 10(6) Special Issue - Minnesota Lake Management Conference Oct. 8-9, 1989, Mpls, MN, NALMS

Table 8. Importance of Lake(s) to Local Economy Worksheet

PROPERTY VALUE IMPACT

1. Surface water acres _____

2a. Number of riparian properties _____

seasonal _____

year-round _____

total properties in county _____

b. Population estimates (demographics) _____

seasonal _____

year-round _____

visitors _____

total county population _____

3a. Median value of properties (based on recent sales) _____

seasonal _____

year-round _____

elsewhere in county** _____

b. Real estate taxes (median based on value and rate) _____

seasonal properties _____

year-round _____

elsewhere in county _____

LOCAL ECONOMIC IMPACT

4. Estimated jobs and dollars in county derived from:
 agriculture _____ industry _____ forestry _____
 tourism _____ other _____

Sum _____

5. Impact on income and employment

a. Employment (at 16.5 jobs/1,000 acres) _____

b. Median family income (riparian)
 retired _____ seasonal _____ permanent _____

c. Consumer purchases (at \$687/lake surface acre)* _____

Value added (at \$501/acre)* _____

d. Tourist expenditure and multiplier _____

INTANGIBLES

6. Consumer's surplus _____

7. Option value _____

COST OF PROTECTION VS. RESTORATION

8a. Dollars spent on lake/watershed management

- by lake association*** _____
- by county _____
- by state or federal government _____

b. Estimated restoration expense

- jobs _____
- dollars _____

* 1985 figures adjusted for inflation to 1992 dollars
 ** city or township estimates could replace county, depending on desired comparison
 *** may want to tally volunteer hours, also

Chapter V

Monitoring Equipment, Sampling, and Laboratory Consideration

a. Sampling Equipment—Construction and Use

The primary tools for collecting water quality samples and taking measurements in the field include: a Secchi disk, a depth sampler, an integrated sampler, and dissolved oxygen and temperature meters. An additional tool might include a plankton net for collecting zooplankton and/or phytoplankton samples. A short description of each, as well as possible homemade alternatives, are discussed further.

Parts of the homemade equipment descriptions are taken from Tennessee Valley Authority (Tennessee Valley Authority, 1991), Wisconsin Department of Natural Resources (Davis et al., 1992), and University of New Hampshire (Davis et al., 1992) volunteer monitoring program descriptions and methods publications.

The *Secchi disk* is the primary tool for measuring the clarity or transparency of a lake. Routine measurement of Secchi transparency over the summer provides information on seasonal, spatial and long-term trends on the quality of a lake. Secchi disks can be obtained inexpensively through the Minnesota Pollution Agency's Citizen Lake Monitoring Program (CLMP). CLMP participants receive a Secchi disk, recording forms, and instructions for their use. Each year, the participant receives new recording forms and an annual report.

Depth samplers allow for the collection of samples at a specified depth, e.g. 1 meter above the bottom of the lake. Two common depth samplers are the Kemmerer and Van Dorn samplers. A homemade (Meyer type) deep water sampler can be constructed and used in place of more expensive Kemmerer or Van Dorn.

The sampler, which is further described in Fig. 10, can be constructed with a clear plastic or heavy glass milk/beverage bottle (preferably with a handle), a rubber stopper (which is sized to fit snugly into the neck of the bottle), an eyebolt, and along nylon rope. The bottle must be weighted in order to drop vertically through the water column. This may be done by partially cementing the bottle in a coffee can, or attaching a rock to the bottom of it.

First, drill a hole in the rubber stopper and then screw the eyebolt through it with washers on either side to prevent leakage. Then, tie the rope onto the eyebolt, leaving a 12 inch tail as shown in Fig. 10. Attach the tail of the rope to the bottle handle or around the neck of the bottle. If you wrap the tail around the neck of the jug, secure it in place with electrical or duct tape. Finally, using a permanent marker, mark off the rope in meter increments, starting from where the rope is attached to the jug handle or neck.

The deep water sampler is used by gently lowering it to the desired depth (determined by the markings on the rope), and making sure that the rubber stopper is securely in place. When the desired depth is reached, a sharp tug on the line will pop the stopper from the bottle. The sampler will then suspend from the rope secured to its handle or neck, and fill with water from that depth. Wait a couple of minutes and gently pull the bottle up by the rope. Empty the contents into a clean sampling jar and store in a ice chest until delivered to the laboratory for preservation (if not preserved in the field) and analysis. Kemmerer and Van Dom samplers are operated the same way, except they are lowered in an open position and are closed by sending a weight (messenger) down the rope to trip the closing mechanism.

FIGURE 10. —Lake and stream sampling equipment.

Integrated Sampler

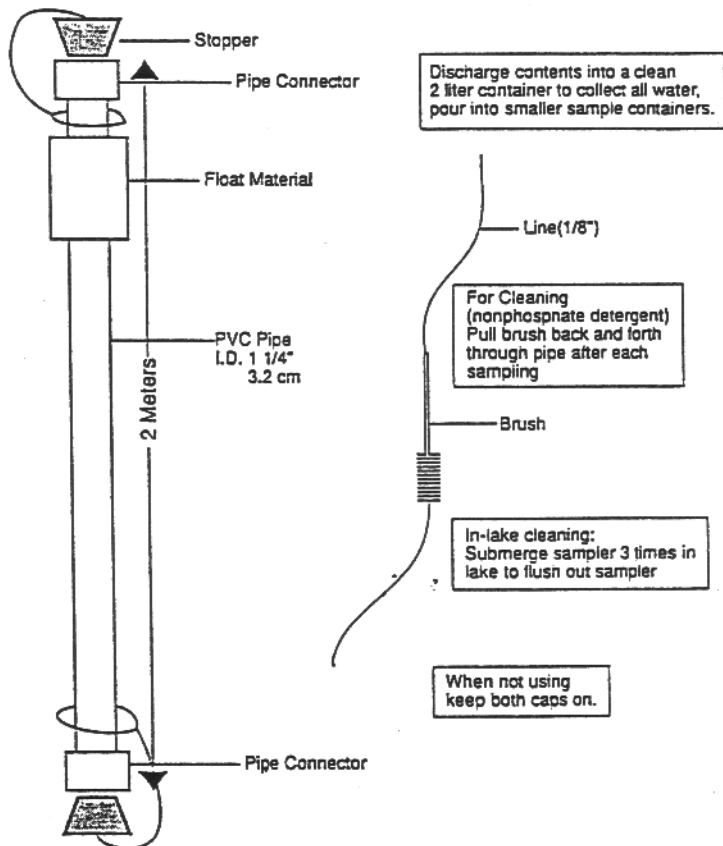

Note: We could provide rubber stoppers (the green stoppers in the lab)

MAKING A DEEP WATER SAMPLER

Need:

- ▶ Clear plastic milk or beverage container (at least 2 liter)
- ▶ Nylon rope marked in 1-meter intervals with permanent marker
- ▶ Rubber stopper
- ▶ Rock, or other suitable weight
- ▶ Duct or electrical tape

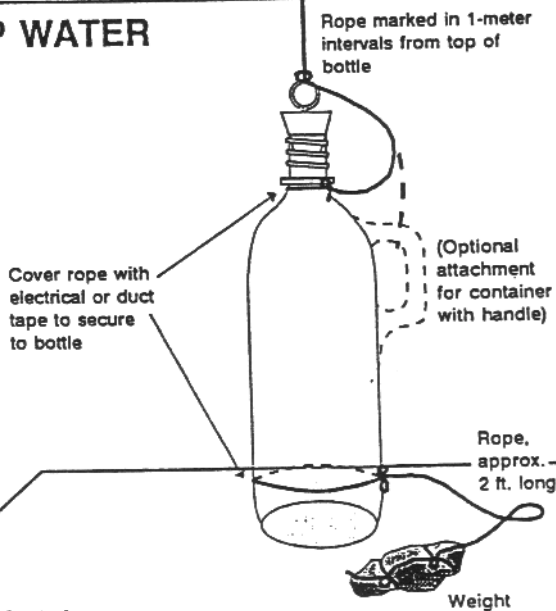

Adapted from TVA Water Quality Series Booklet 2, *Homemade Sampling Equipment*

FIGURE 10. —continued

MAKING A LAKE PLANKTON SAMPLER

Need:

- ▶ Pillow case or long shirt cleve
- ▶ 4 wire coathangers
- ▶ Electrical or duct tape
- ▶ Small glass jar
- ▶ Heavy duty rubber band

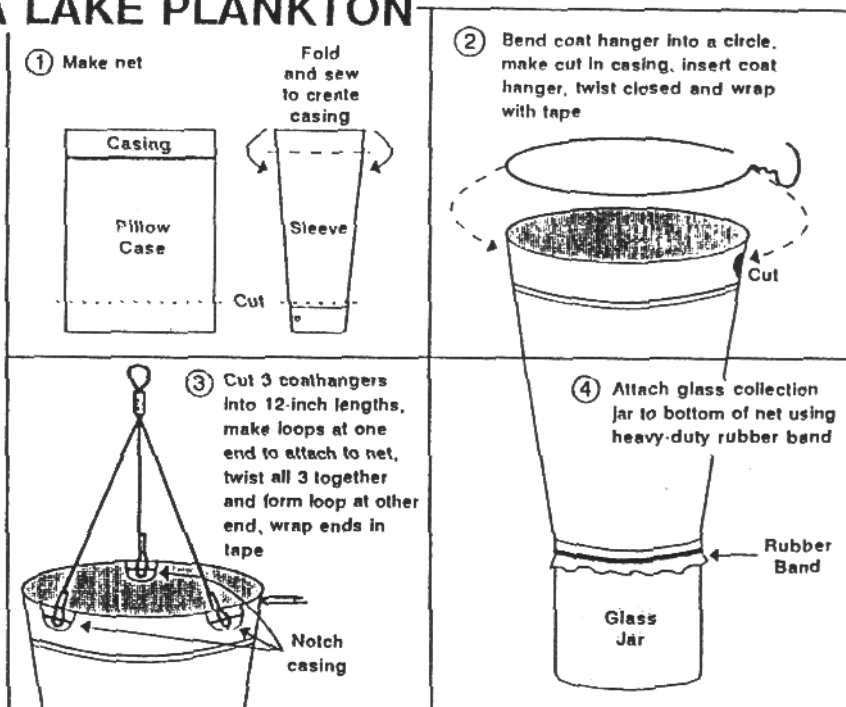

Adapted from TVA Water Quality series
Booklet 2 *Homemade Sampling Equipment*

MAKING A D-NET For Collecting Aquatic Invertebrates

Need:

- ▶ 4 pieces nylon netting (10"x12")
- ▶ 40" strip of bias tape or equivalent cloth scrap
- ▶ Wire coat hanger
- ▶ 4-foot long broom handle or wooden dowel
- ▶ Duct tape

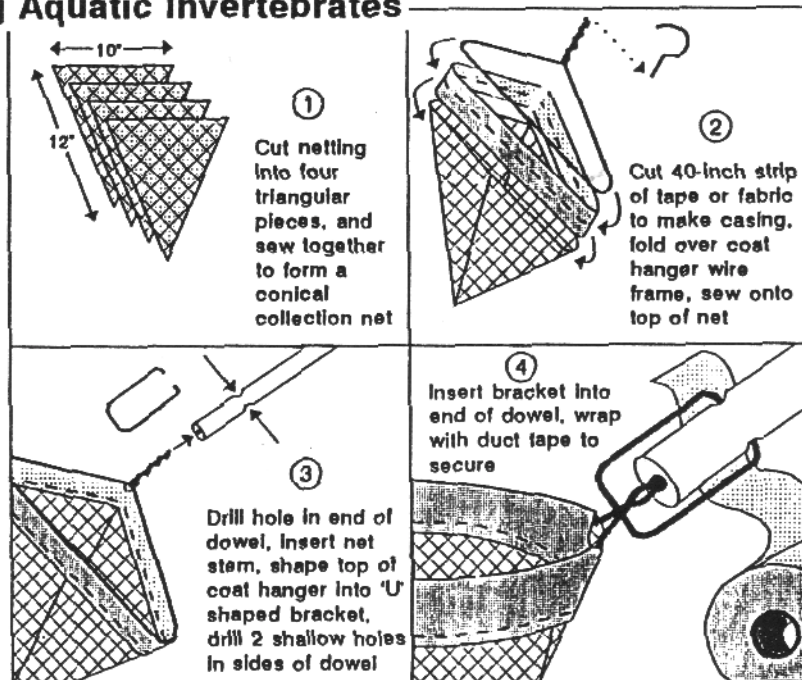

Adapted from TVA Water Quality series
Booklet 2 *Homemade Sampling Equipment*

To ensure quality data, the deep water sampler occasionally should be checked to make sure it works properly. If the sampler leaks at all, water can enter before it reaches the desired sampling depth, thus contaminating the desired sample. To test for leakage, the stoppered sampler can be lowered to a desired depth and left stoppered. After leaving the sampler in the water for a few minutes, it can be raised to determine if any water is inside. If no water leaked in, then the sampler is working properly.

An *integrated (composite) sampler* consists of a specially constructed 2 meter (6.6 foot) long and 3.2 cm (1.25 inch) diameter PVC tube. This is used to collect a composite sample from the surface to a depth of 2 m. It will fill a 2 liter bottle and is used to collect water samples for the majority of the chemical analyses. In shallow lakes that do not stratify thermally (typically lakes with a maximum depth of less than 30 feet) this may be the only sampler needed to collect water samples. Fig. 10 provides specifications for constructing an integrated sampler.

Plankton nets can be used to assess the lake's zooplankton population. One method involves lowering the net to within a meter of the bottom, and then towing it vertically to the surface. The zooplankton are concentrated in the net and collection bucket, and can then be washed into a sample bottle. The sample can then be taken to the laboratory for preservation and taxonomic and quantitative analysis (e.g. estimating the relative abundance of *Daphnia*). This step requires access to a microscope. To achieve a semi-quantitative sample, multiply the distance you towed the net by the area of the mouth of the net. This will give you the volume of water which passed through the net. Then the counted organisms can be expressed in organisms per unit volume.

Commercial plankton nets consist of canvas reinforced cone-shaped nylon net at one end and a collection "bucket" on the opposite end. Commercial plankton nets, however, are expensive. To combat the expense, a homemade plankton net can be constructed with the use of a shirt sleeve or pillowcase, 4 wire coat hangers, a heavy rubber band, a small jar, and a nylon rope. The shirt sleeve or pillowcase will become the cone shaped net, acting as a funnel to the attached jar. The mouth of the "net" will be formed by one of the coat hangers, while the remaining three coat hangers will mold an attachment hook for the rope to be tied to. A more detailed blueprint is shown in Figure 10.

A *dissolved oxygen and temperature meter* is the preferred method for measuring oxygen and temperature in a lake. DO and temperature meters are quite expensive. It is an important piece of equipment to purchase if numerous lakes are to be monitored (e.g. as a part of county water plan monitoring). However, for most lake associations it may not be a high priority item to purchase. Rather, the association should consider coordinating its monitoring efforts with state or local units who may have this equipment.

b. Where, When, and How to Sample

Site selection

In many natural (glacial) lakes in Minnesota it is adequate to sample at one primary site, typically the site of maximum depth, and at a secondary site in another area or bay in the lake. This often provides adequate information to: characterize the open water quality of the lake, document spatial variations in water quality, and calculate summer mean and extreme conditions for such measurements as chlorophyll *a*. Lakes with complex basin morphologies (numerous bays) and reservoirs frequently must be sampled at additional sites to characterize water quality adequately. It is advisable to check with the MPCA (St. Paul or regional offices) to see if there are existing monitoring sites (e.g. CLMP) on your lake prior to beginning your monitoring.

Sampling frequency

The sampling frequency required for adequate results depends on many factors. It is assumed here that a limited budget is available for laboratory analytical work and that the purpose of the sampling is to characterize the trophic status of the lake, determine seasonal (e.g., spring through summer) changes in water quality, and to establish a baseline for assessing future changes in the quality of the lake.

For this purpose, the minimal sampling effort would incorporate monthly chemical sampling from May through September (i.e., five samples) at the primary and secondary sites. This should be augmented by weekly Secchi transparency measurements at one or more stations from mid-June through mid-September. If a more extensive program is desired (e.g., to improve statistical confidence for the trend assessment) it may be desirable to sample from April through October, with twice monthly samples in June through September (as suggested in Table 1). In order to define year to year variability, the chemical monitoring program should be continued for at least two years, and repeated about every five years. Secchi disk monitoring should be conducted indefinitely (every summer).

Table 9. Lake Monitoring Variables and Frequency of Sampling.

Variable	Site		Priority	Cost	Frequency	
	Primary	Secondary			Minimum	Recommended
Epilimnion						
Nutrients						
total phosphorus ²	X	X	High	Mod.	Monthly	Biweekly
ortho-phosphorus	X		Mod.	Mod.	Monthly	Biweekly
total nitrogen	X		High	Mod.	Monthly	Biweekly
Secchi disk ¹		X	X	High	Very low	Monthly
Weekly						
Chlorophyll <i>a</i>	X	X	High	Mod.	Monthly	Biweekly
General Chemistry	X		Mod/Low	High/Low	Monthly	Biweekly
total suspended solids, color, pH, alkalinity, conductivity, turbidity, nitrate + nitrite-N.						
Oxygen and Temp. profile	X	X	High	High/Low	Monthly	Weekly
Field Observations						
Precip.			High	Low	Every Storm	
Lake Level			High	Low	Weekly	Weekly
Macrophyte mapping	X	X	Mod.	Very low	1 X/sum.	2 X/sum.
Plankton analysis	X	X	Mod.	Mod/high	Monthly	Biweekly

¹Includes measures of physical appearance and recreational suitability.

²Collect from the hypolimnion also.

Sample variables

If the primary focus of sampling is to establish the trophic status of the lake (e.g. basic level), it is important to place the most emphasis on the variables we use to characterize trophic status: total phosphorus, chlorophyll *a*, and Secchi disk transparency. A suggested list of variables to measure is presented in Table 9. Note that the majority of the variables measured are collected from the epilimnion (integrated sample) at the primary site. The sample frequency refers to the May to September time period. Those parameters of moderate to low priority can be excluded in a basic assessment.

c. Laboratory Considerations

Observe all rules on proper sample handling, as designated by the laboratory. Contaminated samples are worse than no sample. Things to watch for include proper icing, preservation of samples (e.g. acidification if required), and observing holding times for a given sample. When collecting a hypolimnetic sample, make sure the samples do not come in contact with the lake sediments.

Laboratory analytical techniques and detection limits (lowest concentration detectable by the technique) are frequently a concern. Working with a laboratory certified by the Minnesota Department of Health (MDH) is strongly recommended. A listing of MDH certified laboratories may be obtained through the MDH, Public Health Laboratories Division or the MPCA, Water Quality Division (Appendix III). In particular, laboratories that work with lake samples, rather than wastewater or process water, should be sought since they will most likely have appropriate detection limits. Suggested detection limits (or lower) for key parameters are as follows:

Total phosphorus	0.005 mg/L (ppm)
Kjeldahl nitrogen	0.1 mg/L
Chlorophyll <i>a</i>	0.5 µg/L (ppb)
Ortho-phosphate	0.001 mg/L
Nitrate + Nitrite-N	0.01 mg/L

To ensure quality data, both the monitoring program and analytical laboratory must adopt effective quality assurance/quality control (QA/QC) responsibilities. The monitoring program must be aware of proper sample containers (sizes and materials), proper preservation and proper sampling methods, and/or document methods and materials used. The laboratory, on the other hand, must be able to assure that they are using proper analytical procedures, and that their analytical instruments are working properly and measure accurately. The instruments should be calibrated according to manufacturer's direction, and tested with known standards. All calibrations should

spikes (adding a known concentration to a previously tested sample - the new concentration should then equal the first value plus the spiked amount), dilutions (same concept as spikes, except reducing a previously tested sample by a known amount), and splits (splitting the sample in half and have tests run at two different labs).

Before designing a monitoring program QA/QC plan, the data quality objectives for the program need to be determined. These objectives represent the uncertainty or data variation within the monitoring program which can be tolerated and still fulfill the monitoring needs. U.S. EPA (1991) describes five major areas of uncertainty that should be evaluated when formulating data quality objectives. They are as follows:

- **Accuracy.** Accuracy is the degree of agreement between the sampling result and the true value of the parameter being measured. Accuracy is most affected by the equipment and the procedure used to measure a sample parameter.
- **Precision.** Precision, on the other hand, refers to how well you are able to reproduce the data result on the same sample (regardless of accuracy). Human error in sampling techniques plays an important role in estimating precision.
- **Representativeness.** Representativeness is the degree to which the collected data accurately and precisely represent the lake condition being measured. It is most affected by sample location. For example, if the monitoring objective is to characterize the algal condition in a lake, taking a sample along the shore near an inlet stream may not be a good representation of the conditions in the lake as a whole.
- **Completeness.** Completeness is a measure of the amount of valid data obtained versus the amount expected to be obtained, as specified by the original sampling design objectives. It is usually expressed as a percentage. For example, if 100 samples were scheduled, but volunteers only sampled 90 times because of bad weather, broken equipment and so forth, the completeness record would be 90 percent.
- **Comparability.** Comparability is very important to the manager of a citizen monitoring program because it represents how well data from one lake can be compared to data from another. As part of a statewide or regional report on the volunteer monitoring program, most managers compare one lake to another. It is vital, therefore, that sampling methods and procedures are the same from lake to lake.

Additional information on quality assurance and appropriate sampling methods, sample handling, and analytical procedures may be obtained from the Minnesota Department of Health, Public Health Laboratories Division or the MPCA, Water Quality Division (Appendix III).

Chapter VI

Data Organization, Storage, and Assessment

As data is being collected, it is important to consider how the data will be organized, where it will be stored (e.g. paper files, computer, etc.), and how the data is accessed. A related consideration is, Who can help with these steps? If you are collecting data through existing programs such as MPCA's CLMP or MDNR's Lake Level Program, these steps are taken care of for you. Forms are provided for data entry and, upon receipt of the completed forms, MPCA and MDNR enter the data into permanent databases. This chapter provides some thoughts on how to record, organize and store your information, and provides some data assessment and presentation techniques.

a. Data Organization and Storage

As data is being collected, it is important to record field and laboratory data in such a fashion that it may be stored in existing computer databases or in a form that allows for creation of a database. This may require the use of existing forms such as those used in CLMP and the Lake Level Program. In other cases, special forms can be developed. This discussion will focus primarily on data which can be stored in existing databases, i.e., water quality and lake level data.

Water quality data should be permanently stored in STORET, whenever possible. STORET (stands for STORage and RETrieval) is U.S. Environmental Protection Agency's (U.S. EPA) national water quality data bank. STORET is routinely used by MPCA, Metropolitan Council, U.S. Forest Service, and other public and private organizations. All CLMP data is stored in STORET. The MPCA enters data into the system from a variety of sources, including the MDNR, consultants, local units of government and lake associations. Data entry is quite specific as to who (e.g., agency) collected the data, date, time, and site of collection, laboratory procedures used, etc. STORET data may be accessed directly through the National Computer Center (NCC) for those individuals/agencies with a NCC account. Otherwise, STORET data may be acquired by contacting MPCA, Water Quality Division (Appendix III).

If you are considering having your data entered into STORET, it is suggested that you contact MPCA, Water Quality Division (Appendix III) prior to data collection, so appropriate forms (either paper or computer) can be developed for tabulating your data. MPCA staff can inform you of existing data for your lake. Good reasons for storing your data in STORET are to make it part of a permanent database, to facilitate analysis of the data, and to strengthen your database by combining it with other data from the same lake (e.g., CLMP).

Example field sheets and laboratory bench sheets are included in Appendix II (Tables 6 and 7). Both sheets allow for direct entry of data into STORET. The field sheet includes a variety of other observations, which can aid in the overall analysis of the lake. Laboratory sheets can be made specific to a given study or laboratory.

b. Data Assessment and Presentation

Once the sampling and data gathering is completed, it is necessary to organize the information for efficient evaluation of the data. Table 8 (Appendix II) is an example of a good way to tabulate the basic lake morphometry and watershed data.

The next step is to organize the water quality data and calculate some basic statistics. This can be easily done if the data has been stored in STORET. At a minimum, data should be entered into a computer spreadsheet or other database to facilitate analysis. This may make it easier to put the data into STORET at a later date.

In general, we are interested in calculating summer mean concentrations of the parameters we have measured. Summer is loosely defined as mid-June through mid-September. Data collected in the spring (May) and in the fall should be excluded from the calculation. The statistics noted in Table 9 (Appendix II) would be a routine output from a statistical package such as Statistical Analysis System (SAS), which is available through STORET.

The next step is to evaluate the data for the lake. One way to place the information in perspective for your lake is to compare the values to those found in reference lakes from the same ecoregion your lake is located in. Ecoregions were mapped for the United States from information on soils, landform, potential natural vegetation and land use, were mapped for the United States from information on soils, landform, potential natural vegetation and land use, by the U.S. EPA. For Minnesota, within-region similarities in terms of quality and lake morphometric characteristics

have been noted (Heiskary and Wilson, 1989 and 1990). Reference lakes, deemed to be representative and minimally impacted by man (e.g. no point source wastewater discharges, no large urban areas in the watershed, etc.), were sampled in each ecoregion by MPCA. Data from these lakes can then be used as a “yardstick” to compare your data against. Table 10 (Appendix II) provides a summary of values for each parameter and each ecoregion. These values were taken from the “inter-quartile range” (25th to 75th percentile) of the summer-mean values for the reference lakes for each region. By using these values, we have excluded the very low values (lower 25%) and the very high values (upper 25%) and thus have a range of values which represent the central tendency of the reference lake’s water quality. (To determine the interquartile range, you sort the data from the lowest to the highest values and assign a rank to each. If you have 100 lakes, the middle 50 (lakes), from 26-75, represent the interquartile range.)

Carlson’s Trophic State Index

R.E. Carlson

TSI < 30	Classical oligotrophy: Clear water, oxygen throughout the year in hypolimnion, salmonid fisheries in deep lakes.
TSI 30-40	Deeper lakes still exhibit classical oligotrophy, but some shallower lakes will become anoxic in the hypolimnion during the summer.
TSI 40-50	Water moderately clear, but increasing probability of anoxia in hypolimnion during summer.
TSI 50-60	Lower boundary of classical eutrophy: Decreased transparency, anoxic hypolimnia during summer.
TSI 60-70	Dominance of blue-green algae, algal scums probable, extensive macrophyte problems.
TSI 70-80	Heavy algal blooms possible throughout the summer, dense macrophyte beds, but extent limited by light penetration. Often would be classified as hypereutrophic.
TSI >80	Algal scums, summer fish kills, few macrophytes, dominance of rough fish.

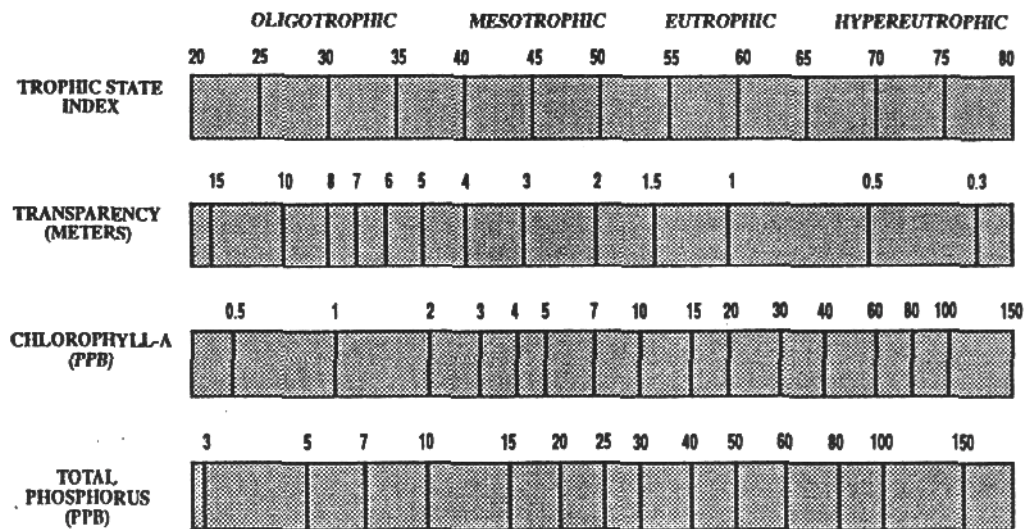

After Moore, I. and K. Thornton, [Ed.] 1988. Lake and Reservoir Restoration Guidance Manual. USEPA> EPA 440/5-88-002..

Figure 11.

The values from Table 10 (Appendix II) can be inserted into Table 9 (Appendix II), allowing for a quick visual comparison between your lake data and the reference lake data. Given this comparison, a parameter by parameter assessment of the data from your lake can be made.

In addition to evaluating your data relative to the reference lakes, it is also helpful to employ some other basic analytical techniques to evaluate your data and do a better job of characterizing the condition of your lake. Some examples have been previously noted in the text (chapter 2). Further suggestions follow.

Assessing the *trophic status* of your lake is a good starting point. Total phosphorus, Secchi transparency and chlorophyll a are the basic parameters that go into characterizing the “trophic status” of a lake. Lakes in Minnesota range from *oligotrophic*—very low nutrients and algae, to *hypereutrophic*—very high nutrients and algae. Carlson’s Trophic State Index (TSI) is a standard means for calculating the trophic status of a lake. The index is based on the interrelationships of these parameters. Fig. 11 graphically depicts the index. If the index values agree fairly well for your lake, it may be safe to assume that given data for one of the parameters, e.g., Secchi transparency, you should be able to estimate the others and, ultimately, be able to track changes in trophic status over time.

Lake water quality modeling (nutrient mass-balance) provides a means for assessing the impact of tributary nutrient and water loads on the condition of the lake. Various models are available for estimating nutrient (phosphorus) and water budgets for lakes. These models provide a means for relating the flow of water and nutrients from the watershed to observed conditions in the lake. Alternatively, they may also be used for estimating changes in the quality of the lake as a result of altering nutrient input. Three models are commonly used in Minnesota for that purpose.

The first—*MINLEAP*, the “Minnesota Lake Eutrophication Analysis Procedure”—was developed by MPCA staff and is based on an analysis of data from the ecoregion reference lakes. The only inputs needed to run this model are: lake surface area, mean depth, watershed area (minus lake area), the ecoregion the lake is in, and summer mean measures of total phosphorus, chlorophyll *a* and Secchi transparency. The model provides water and phosphorus budget estimates and estimates of in-lake conditions which can be compared to observed conditions. Further details on this model are provided in Wilson and Walker (1989). This model is used as a part of a basic level of assessment.

The second model, referred to as “*Reckhow - Simpson*,” uses the same basic inputs but, in addition, requires information on land use and shoreland residences. Phosphorus export coefficients are assigned to the various land use categories. The *Reckhow - Simpson model* calculates individual phosphorus loads for each land use category, a total load to the lake, and predicts in-lake conditions. This model is particularly useful for estimating the relative contribution of phosphorus by the various land uses and also provides a means to estimate the impact of land use changes in the watershed on in-lake conditions. Further details on this model are provided in Wilson (1990). This model is used as a part of an intermediate assessment.

BATHTUB is an empirically derived model based on data from U.S. Army Corps of Engineers reservoirs from around the United States. It consists of a series of nutrient balance and eutrophication response models. *BATHTUB* is routinely used by MPCA and other entities in the state for examining point and nonpoint source impacts on lakes and reservoirs throughout the state. It is the model of choice for most Clean Water Partnership and Clean Lakes studies in Minnesota and should be used in advanced assessments. Further details on *BATHTUB* may be found in Walker (1986).

Once all the information is summarized and analyzed for the lake, it is often helpful to establish a *water quality goal*—typically a phosphorus goal—for the lake. This goal can be an integral part of the lake management plan. Goal setting should also incorporate fishery and lake use considerations. This is addressed in greater detail in *Developing a Lake Management Plan* but, in general, a water quality goal is derived by:

- a) A comparison of in-lake conditions relative to the appropriate reference values for that ecoregion;
- b) User perceptions relative to Secchi transparency and chlorophyll *a*, related back to a phosphorus concentration;
- c) Evidence of long-term trends based on actual data and lake history information;
- d) An understanding of year-to-year variation in lake condition (often the result of varying levels of precipitation and runoff); and
- e) A review of the modeling results (predicted in-lake conditions) and the reasonableness of the predictions.

Compiling the above information, plus information from the fishery management plan and information on lake uses, should result in the selection of a reasonable water quality goal which would serve to protect/improve the overall health of the lake.

Chapter VII

Summary and Conclusions

Gathering and analyzing information on your lake and its watershed are essential to effectively manage the lake. This manual provides basic information, methods for acquiring, and methods for analyzing the information. Topics addressed include the assessment of lake characteristics (including geographic, physical, chemical and biological characteristics), watershed characteristics (including watershed delineation, land use assessment, shoreland development and tributary monitoring), and a variety of miscellaneous characteristics (status of on-site systems, lake and watershed history, lake uses, climatic, and economic significance of the lake). Each topic area includes information which can be used in, or contribute to the *lake management plan*.

Even though you may not initially be interested in acquiring all the information suggested in this manual, it should serve as a ready resource as you become more involved in the management of your lake.

As your involvement in lake management increases, the significance of the information included in this manual will become more apparent than may be the case initially. Questions which may arise could include: Where should we start gathering information on our lake and watershed? Should we implement a monitoring program? What comes first, data gathering or developing a lake management plan? Answers to these questions may vary, depending upon who you ask. We offer the following as a possible approach.

Before initiating data gathering or monitoring, check with local government and state agencies to see what is already available for your lake and watershed. Contacts and agency responsibilities have been noted throughout the manual. For example, the local water plan, available through the county or designated water management organization, may provide a wealth of information on your lake and watershed. Water quality data may already be available for your lake-check with the MPCA, Water Quality Division. Your lake level may already be monitored-check with the DNR, Division of Waters. The list goes on-when in doubt check first; determine objectives for monitoring, second; and monitor, third.

Approach lake and watershed assessment in phases (levels), beginning with rather basic (low cost) and proceeding to more advanced (high cost) assessment techniques, as manpower and budget allow. Table 1 presents a potential hierarchy of lake and watershed assessment.

The “basic” level of assessment provides a good starting point in your quest for information on your lake and watershed. Upon completion of this assessment you will be able to characterize summer-mean water quality conditions, lake level fluctuations, make basic water quality and morphometric comparisons with other lakes in your ecoregion, understand the fishery management of the lake, gain an appreciation of uses of your lake, and problems that may be encountered. Further, a basic assessment will place you in a position to communicate facts about your lake to shoreland property owners, lake users, and local decision makers. You are also ready to begin developing a lake management plan. Lake management planning could take place before completion of a “basic” assessment, but by completing a basic level of assessment, you will have acquired information which is essential for managing your lake. This information should help the planning process to proceed more efficiently and quickly.

As you move on to intermediate and advanced assessments, you will gain even more information on your lake and its watershed. The additional information gained in these steps will improve your ability to help manage and protect the conditions of your lake.

Acquiring accurate information on a lake and its watershed is an essential step in the overall management of the lake. Citizens, lake associations, and local units of government can play an important role in acquiring this information and assessing lake condition. This manual provides you with the basic information needed to design monitoring programs, acquire information, and begin to assess lake and watershed condition. The companion manual, *Developing a Lake Management Plan* will help you to use this information to promote beneficial management of your lake.

References

- Anhom, R.A. 1992. Handbook for the Citizen-Assisted Lake Monitoring Program. Metropolitan Council. St. Paul, MN.
- Betz, C.R., and J. Schloss. 1992. Cent-Saving Samplers, Secchis and Scopes, pp. 82-84 *in* Proceedings of the Third National Citizen's Volunteer Water Monitoring Conference, March, 1992. Annapolis, Maryland. EPA 841-R-92-004.
- Carlson, R.A. and J.B. Moyle. 1968. Key to the common aquatic plants of Minnesota. Spec. Pub. No. 53. MN Dept. of Conservation.
- Davis, W., C. Weber, D. Duff, and F. Mangum. 1992. River and Stream Monitoring Techniques, pp. 148-151 *in* Proceedings of the Third National Citizen's Volunteer Water Monitoring Conference, March, 1992. Annapolis, Maryland. EPA 841-R-92-004.
- Duarte, Carlos M. and Jacob Kalf. 1990. Patterns in the submerged macrophyte biomass of lakes and the importance of the scale of analysis in the interpretation. *Can. J. Fish. Aquat. Sci.* 47:357363.
- Eilers, J.M., G.E. Glass, K.E. Webster, and J.A. Rogalla. 1983. Hydrologic control of lake susceptibility to acidification. *Can. J. Fish Aquat. Sci.* 40:1896-1904.
- Eggers, Steven D. and Donald M. Reed. 1987. Wetland Plans and Plant Communities of Minnesota and Wisconsin. U.S. Army Corps of Engineers, St. Paul District. 201 pp.
- Fassett, Norman C. 1957. A Manual of Aquatic Plants. University of Wisconsin Press. 405 pp.
- Heiskary, S.A. and C.B. Wilson. 1989. The regional nature of lake water quality across Minnesota. An analysis for improving resource management. *Jour. Minn. Acad. Sci.* 55 (1):71-77.
- Heiskary, S.A. and C.B. Wilson. 1990. Minnesota lake water quality assessment report. MN Pollut. Cont. Agency. St. Paul, MN.
- Heiskary, S.A., and W.J. Munson. 1991. Lake Water Quality Assessment: A State Perspective, pp. 11- 19 *in* Proceedings of the Third Annual Minnesota Lake Management Conference, Oct. 1991, Alexandria, MN.
- Hotchkiss, Neil. 1972. Common Marsh, Underwater and Floating-leaved Plants of the United States and Canada. Dover Publications, Inc. 124 pp.
- Illinois Department of Energy and Natural Resources. 1990. Citizen Stream Monitoring: A Manual For Illinois. ILENR/RE-WR-90/18.
- Jessen, Robert and Richard Lound. 1962. An evaluation of a survey technique for submerged aquatic plants. Game Investigational Report No. 6. Minnesota Department of Natural Resources. 10 pages.
- Lime, David W., Leo H. McAvoy, David G. Pitt and Curtis Schatz. 1990. Minnesota Boat Owners: A summary of who they are and what they want. University of Minnesota Extension Services. 4 pp.
- Lyon, A.E. 1992. Make It Yourself, pp. 81-82 *in* Proceedings of the Third National Citizen's Volunteer Water Monitoring Conference, March, 1992. Annapolis, Maryland. EPA 841-R-92-004.
- McAvoy, Leo H., David W. Lime, Curtis Schatz and David G. Pitt. 1990. Management of boating in Minnesota: problems and actions. University of Minnesota Extension Service. 5 pp.
- Minnesota Department of Natural Resources. 1993. Manual of Instructions for Lake Survey. Spec. Pub. No. 147. Div. of Fish and Wildlife, Section of Fisheries, St. Paul, MN.
- Minnesota Pollution Control Agency and Freshwater Foundation. 1985. A Citizen's Guide to Lake Protection. Minnesota Pollution Control Agency. St. Paul, MN.
- Minnesota Pollution Control Agency. 1986. Protecting Minnesota's Waters ... Land Use Connection. St. Paul, MN.

- Moore, L. and K. Thornton. 1988. Lake and reservoir restoration manual. Prepared by North Am. Lake Management Society for U.S. EPA. EPA 440/5-88-002.
- New York State Department of Environmental Conservation. 1990. Diet for a Small Lake: A New Yorker's Guide to Lake Management. Federation of Lake Associations, Inc. Rochester, New York.
- Nickels, A.B. 1992. Citizens Monitor Water Quality. *Water Environment & Technology*. March 1992, pp. 55-59.
- Nielsen, L.A., and D.A. Johnson. 1983. *Fisheries Techniques*. American Fisheries Society. Bethesda, Maryland.
- Osgood, R.A., and G.L. Oberts. 1989. An Evaluation of Lake and Stream Monitoring Programs in the Twin Cities Metropolitan Area. Metropolitan Council Publ. 590-89-128.
- Penaloza, Linda J. 1991. Boating on Lakes Mendota and Monona. Wisconsin Department of Natural Resources. 3 pp.
- Pitt, David G., Curtis Schatz, David W. Lime and Leo H. McAvoy. 1990. Activities at free public water access sites. University of Minnesota Extension Service. 5 pp.
- Plafkin, J.T., M.T. Barbour, K.D. Porter, S.K. Gross, and R.M. Hughes. 1989. Rapid bioassessment protocols for use in streams and rivers: benthic macroinvertebrates and fish. U.S. EPA Office of Water, Washington, D.C. EPA 440/4-39-001.
- Rapp, G. Jr., J.D. Albert, B.W. Liukkonen, and J.A. Ilse. 1985. Acid deposition and watershed characteristics in relation to lake chemistry in northeastern Minnesota. *Environ. Int.* 11:425-440.
- Schatz, Curtis, David W. Lime, Leo H. McAvoy and David G. Pitt. 1990. Boating patterns and behavior. University of Minnesota Extension Service. 6 pp.
- Simpson, J.T. 1991. Volunteer Lake Monitoring: A Methods Manual. EPA 440/4-91-002.
- Tennessee Valley Authority. 1991. Booklet I of Water Quality Series: Water Quality Sampling Equipment. Tennessee Valley Authority.
- Tennessee Valley Authority. 1991. Booklet 2 of Water Quality Series: Homemade Sampling Equipment. Tennessee Valley Authority.
- Titus, John E. 1993. Submerged macrophyte vegetation and distribution within lakes: line transect sampling. *Lake and Reserv. Manage.* 7(2):155-164.
- U.S. EPA. 1991. Volunteer lake monitoring: a methods manual. U.S. EPA. Office of Wetlands, Oceans and Watersheds. Washington, D.C. EPA440/4-91-002.
- Walker, W.W. Jr. 1986. Empirical methods for predicting eutrophication in impoundments; Report 7, Phase III: applications manual. Tech. Report E-81-9, prep. for U.S. ACE Waterway Experiment Station, Vicksburg, Miss.
- Wetzel, R.G. 1975. *Limnology*. W.B. Saunders Co. Philadelphia.
- Whitfield, P.H. 1988. Goals and data collection designs for water quality monitoring. *Wat. Resour. Bull.* 24:775-780.
- Wilson, C.B. and W.W. Walker, Jr. 1989. Development of lake assessment methods based upon the aquatic ecoregion concept. *Lake Reserve. Manage.* 5(2)11-22.
- Wilson, C.B. and D. Schuler. 1991. Stream sampling considerations for lake and watershed assessments. pp 35-47 in *Enhancing the States Lake Management Programs, 1991*. NIPC and U.S. EPA, Chicago, IL.
- Wilson, C.B. 1990. Lake water quality modeling: an overview of the basics. pp. 133-141. in *Enhancing State's Lake/Wetland Programs, 1990*. U.S. EPA, NALMS, NIPC, Chicago, IL.
- Zumbege, J.H. 1952. The lakes of Minnesota: their origin and classification. Univ. of Minn., Minn. Geologic Survey, Univ.

Chapter IX

Glossary

Aquatic Macrophyte - macroscopic (larger) forms of aquatic vegetation; encompasses macroalgae, liverworts, mosses, horsetail and ferns, and flowering plants.

Chlorophyll - the primary photosynthetic pigment in plants; a measure of the concentration of algae in lakes.

Cultural Eutrophication - accelerated aging, or rate of eutrophication, of a lake as a result of human activities.

Decomposition - the process in which organisms such as bacteria feed on the remains of plants and animals.

Dissolved Oxygen - the oxygen dissolved in water which is then available for respiration.

Epilimnion - the warm, relatively less dense top layer of water in a stratified lake.

Eutrophication - a natural process of nutrient enrichment whereby lakes gradually become more productive.

Eutrophic Lake - a lake with a high rate of nutrient cycling and, thus, a high level of biological productivity.

Fall Turnover - a mixing process that occurs in autumn in a stratified lake whereby the surface water layer mixes with the bottom water layer.

Food Chain - a sequence of organisms, such as green plants, herbivores, and carnivores, through which energy and materials move within an ecosystem (lake).

Hypolimnion - the cold, relatively dense bottom layer of water in a stratified lake.

Inverse Stratification - condition where warm water lies beneath colder water in a vertical temperature profile; winter stratification below ice cover.

Invertebrate - animals without backbones such as zooplankton.

Limnetic Zone - the area of open water in a lake where zooplankton and phytoplankton are found.

Littoral Zone - referring to the marginal region of a body of water; the shallow, near-shore region; often defined by the band from zero depth to the outer edge of the rooted plants.

Macrophytes - rooted aquatic plants.

Mesotrophic Lake - a lake with a moderate rate of nutrient cycling and biological productivity; between oligotrophic and eutrophic.

Morphometry - physical characteristics of the lake basin, e.g. surface area and maximum depth.

Nonpoint Source - pollution sources in the landscape that are not discharged from a single point, e.g. agricultural runoff.

Oligotrophic Lake - a lake with a low rate of nutrient cycling and a low level of biological productivity (i.e. low nutrients and low algae concentration).

Phosphorus - a primary nutrient that is usually the limiting factor for vegetative growth in natural waters.

Photosynthesis - the process by which green plants transform light energy into food energy.

Phytoplankton - (algae) free-floating, mostly microscopic, aquatic vegetation; the base of the lake's food chain.

Plankton - floating organisms whose movements are more or less dependent on currents; e.g. phytoplankton and zooplankton.

Point Source - (pollution) specific sources of nutrient or polluted discharge to a lake or stream; discharges from a single discernible outlet;

Pollution - a change in the concentration of a material or form of energy, or the introduction of a material or a form of energy, that adversely affects the well-being of organisms.

Profundal Zone - the area in a lake below the limnetic zone where light does not penetrate; this area roughly corresponds to the hypolimnion layer of water and is home to organisms that break down and consume organic matter.

Respiration - the liberation of energy from food within an organism; using oxygen and releasing energy for growth.

Secchi Disk - a device used to make visual estimates of the clarity of water and the depth of light penetration in lakes.

Spring Turnover - a mixing process that occurs in the spring in a stratified lake whereby surface waters mix with bottom waters.

Thermocline - a density gradient owed to changing temperatures; the thermocline is the imaginary plane (below the epilimnion) at the depth where the rate of temperature change is the greatest in a vertical profile; during the summer months.

Trophic Status - the level of growth or productivity of a lake as measured by phosphorus content, algae abundance (chlorophyll content), and depth of light penetration.

Watershed - the geographical region that drains into a lake, river, or stream.

Zooplankton - weakly swimming, mostly microscopic aquatic animals found near the water surface.

COMMONLY USED ACRONYMS

ASCS	Agricultural Stabilization and Conservation Service
APM	Aquatic Plant Management
BMP	Best Management Practice
CLMP	Citizens Lake Monitoring Program
DO	Dissolved Oxygen
DOW	Division of Water
EPA	Environmental Protection Agency
LAP	Lake Assessment Program
LLM	Lake Level Minnesota Program
LMIC	Land Management Information Center
MDNR	Minnesota Department of Natural Resources
MINLEAP	Minnesota Lake Eutrophication Analysis Procedure
MPCA	Minnesota Pollution Control Agency
NCC	National Computer Center
OP	Ortho-Phosphorus
QA/QC	Quality Assurance/Quality Control
SAS	Statistical Analysis System
SCS	Soil Conservation Service
STORET	(Data) Storage and Retrieval
SWCD	Soil and Water Conservation District
TDP	Total Dissolved Phosphorus
TKN	Total Kjeldahl Nitrogen
TN	Total Nitrogen
TSI	Trophic State Index
TSS	Total Suspended Solids
TVs	Total Volatile Solids
TVA	Tennessee Valley Authority
USGS	United States Geological Survey
WDNR	Wisconsin Department of Natural Resources